

Three-field Ionization Chamber
Calibration Procedure for Pre-Amplifier board 60667

The following adjustments apply to the calibration of a 60667 pre-amplifier board for a stationary 3-field ion chamber, e.g. for chest or table use.

WARNING:

- This service manual is available in English only.
- If a customer's service provider requires a language other than English, it is the customer's responsibility to provide translation services.
- Do not attempt to service the equipment unless this service manual has been consulted and is understood.
- Failure to heed this warning may result in injury to the service provider, operator or patient from electric shock and mechanical or other hazards.

This document represents proprietary information originated by Advanced Instrument Development, Inc. and which shall not be disclosed or utilized in any manner detrimental to the company's business.

The procedure assumes that the installation of the Automatic Exposure Control (AEC) is complete and that the AEC and x-ray generator are in proper working condition. After making the necessary interconnections between the ion chamber and the AEC, power up the system.

Calibration/Test Set Up:

Select the center field of the ion chamber. Set the generator for 100 kVp and maximum backup time. For 100 kVp use 8 to 10 inches (20 to 25 cm) of water or plastic for a phantom. Metals such as copper, aluminum or lead are not suitable for use as phantoms. Make sure the phantom is homogeneous and completely covers all fields equally. Center the x-ray beam on the center field. Collimate the x-ray beam so that it completely covers all three fields but does not extend beyond the limits of the phantom.

Chamber Gain Adjustment (P1):

Typically, the chamber gain adjustment is the only adjustment needed when installing an ICX series ion chamber. Use the chamber gain adjustment to match the overall chamber sensitivity to that of the other stationary chambers connected to the system. Note that the chamber gain adjustment is a multi-turn potentiometer. A clockwise adjustment to the chamber gain potentiometer will increase the sensitivity of the chamber, causing the length of the exposure (mAs) to decrease.

Make exposures and process the films. Adjust the chamber gain for the desired optical density. Make the chamber gain adjustment for each stationary chamber being installed.

Balance Check:

Using the Expos-AID AEC post-exposure mAs display or other calibrated mAs meter check the individual fields to see that they are balanced, that is, that they produce the same mAs reading. If mAs readings are not stable from exposure to exposure for an individual field, then it will be necessary to expose films and make these adjustments based upon optical density.

The individual gain potentiometers (P3, P5, and P7) correspond to ion chamber fields 2, 1 and 3 respectively. If necessary, adjust the individual gain potentiometers to balance the outputs to give the same mAs reading for each field. Note that individual gain adjustments are multi-turn potentiometers. A clockwise adjustment to a gain potentiometer will increase the sensitivity of a field, causing the length of the exposure (mAs) to decrease.

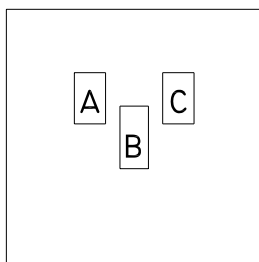

Field A=2, Field B=1, Field C=3 for Models: ICX153, ICX155, ICX170, ICX171, ICX175, ICX905.

Field A=1, Field B=2, Field C=3 for Models: ICX150, ICX151, ICX152.

Drift Adjustments:

The Drift Adjustments (P2, P4, and P6) are preset at the factory for a rate <math>< 30\text{mV}/10\text{ seconds}</math>. They are not to be adjusted on site. If the drift adjustments are incorrect return the ion chamber to the factory for recalibration.

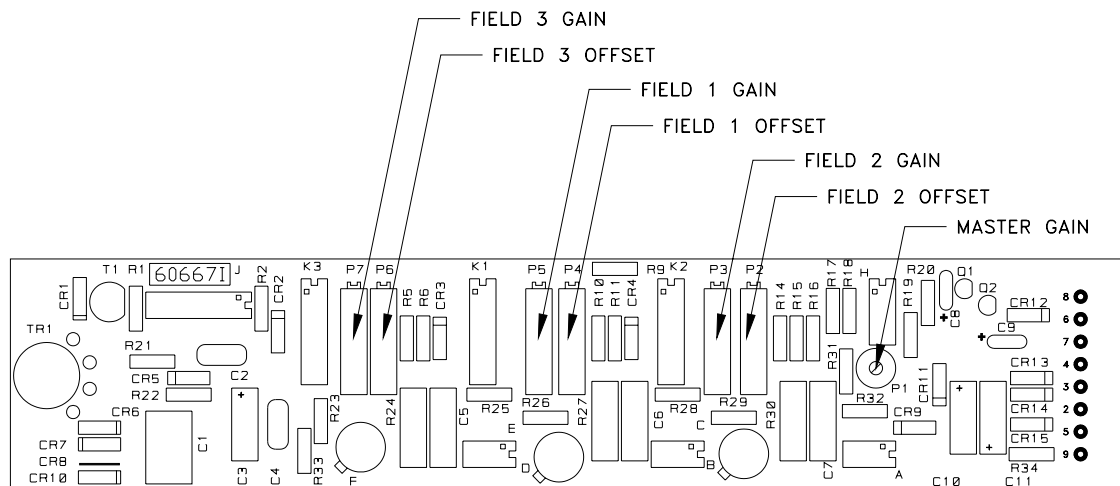

Ionization Chamber Pin outs:

9-PIN SUB-D PIN NUMBER	FUNCTION
1	NO CONNECTION
2	FIELD 2 SELECT
3	FIELD 1 SELECT
4	RESET
5	OUTPUT
6	FIELD 3 SELECT
7	-15VDC
8	+15VDC
9	GROUND*

*Shield is attached only on the ion chamber (female connector) end of the cable.

NOTE: Cable wire colors do not match those inside the pre-amp chassis. Cable pin-out details are available on-line at <http://www.aidxray.com> or by contacting Advanced Instrument Development, Inc.

Acceptable Power Supply Ranges for 60667I Pre-amp:

Supply Voltage	Measurement Point	Acceptable Range	
(Pos. Input Supply Voltage) +12VDC	60667I pin 8	From +11.4VDC to +12.6VDC	
(Neg. Input Supply Voltage) -12VDC	60667I pin 7	From -11.4VDC to -12.6VDC	
(Regulated on board) +5VDC	60667I C8 (positive lead)	From +4.7VDC to +5.3VDC	
(Regulated on board) -5VDC	60667I C9 (negative lead)	From -4.7VDC to -5.3VDC	
Internal Bias Voltage Regulated on board	+75VDC	60667I C1 at the cathode of CR6	From +65VDC to +85VDC
	Or +200VDC	60667A to 60667H C1 at the cathode of CR6	From +170VDC to +230VDC

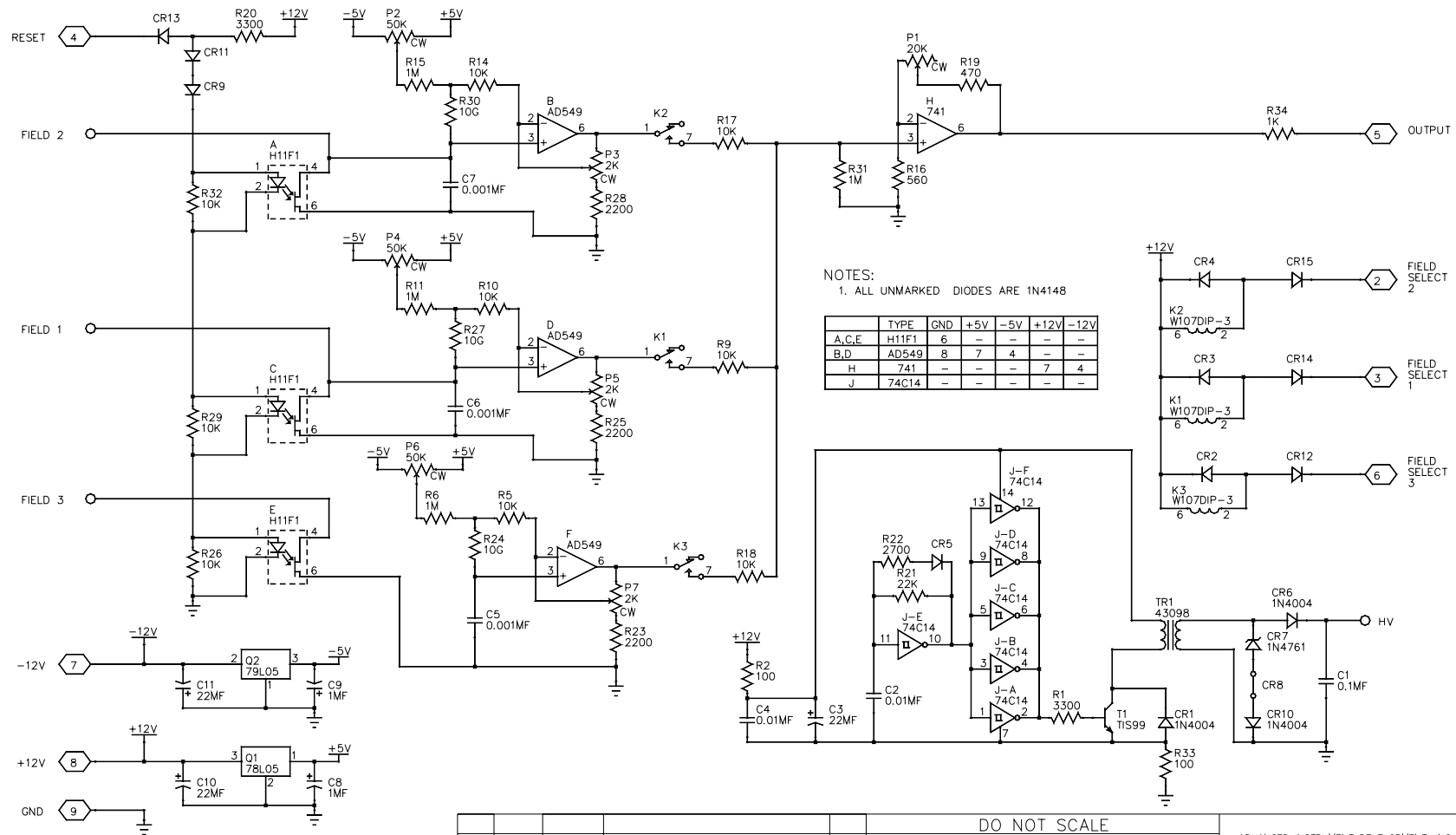

NOTES:
1. ALL UNMARKED DIODES ARE 1N4148

	TYPE	GND	+5V	-5V	+12V	-12V
A,C,E	H11F1	6	-	-	-	-
B,D	AD549	8	7	4	-	-
H	741	-	-	-	7	4
J	74C14	-	-	-	-	-

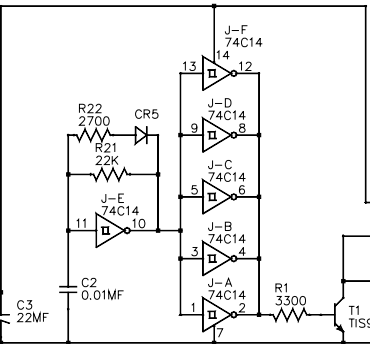

					DO NOT SCALE			ADVANCED INSTRUMENT DEVELOPMENT, INC. 1011 N. 25TH AVE. MELROSE PARK, ILL. 60160					
					UNLESS SPECIFIED OTHERWISE; DIMENSIONS ARE IN INCHES. FRACTIONS DECIMALS ANGLES			X-RAY					
					SCALE	DRAWN BY	DATE						
					NONE	E.G.S.	17FEB94						
					MATERIAL	CHECKED BY							
					FINISH	APPROVED BY							
					THIS DRAWING REPRESENTS PROPRIETARY AND CONFIDENTIAL INFORMATION ORIGINATED BY ADVANCED INSTRUMENT DEVELOPMENT, INC. AND WHICH SHALL NOT BE DISCLOSED OR UTILIZED IN ANY MANNER DETRIMENTAL TO THE COMPANY'S BUSINESS.					USED ON	NEXT ASSY.	DRAWING NO.	REV.
					REV.	ECN NO.	DATE	REVISIONS	BY	ICX SERIES		606671	01