

Three-field Ionization Chamber
Calibration Procedure for Pre-Amplifier board 60917F

The following adjustments apply to the calibration of a 60917F pre-amplifier board for a stationary 3-field ion chamber, e.g. for chest or table use. (Also valid for 60917G, 60917I, 60917J and 60917P).

Pre-amp Assembly	Description	Difference from 60917F
60917F	3-Field Pre-amp, Standard Gain	None
60917I	3-Field Pre-amp, Wide Field-Gain Range	Omit D17, D8 & D9 = 1N4148 R6 = 3300 ohm R15, R25 & R32 = 100K ohm R33 = 12K ohm
60917J	3-Field Pre-amp, Uneven Field-Gain Ranges	Omit D17, D8 & D9 = 1N4148 R6 = 3300 ohm R25 & R32 = 100K ohm R33 = 12K ohm
60917P	3-Field Pre-amp, High Gain 150V Internal Bias Voltage	D3 = 1N4761 R9 = 1200 ohm R12 = 50K ohm

WARNING:

- This service manual is available in English only.
- If a customer's service provider requires a language other than English, it is the customer's responsibility to provide translation services.
- Do not attempt to service the equipment unless this service manual has been consulted and is understood.
- Failure to heed this warning may result in injury to the service provider, operator or patient from electric shock and mechanical or other hazards.

This document represents proprietary information originated by Advanced Instrument Development, Inc. and which shall not be disclosed or utilized in any manner detrimental to the company's business.

The procedure assumes that the installation of the Automatic Exposure Control (AEC) is complete and that the AEC and x-ray generator are in proper working condition. After making the necessary interconnections between the ion chamber and the AEC, power up the system.

Calibration/Test Set Up:

Select the center field of the ion chamber. Set the generator for 100 kVp and maximum backup time. For 100 kVp use 8 to 10 inches (20 to 25 cm) of water or plastic for a phantom. Metals such as copper, aluminum or lead are not suitable for use as phantoms. Make sure the phantom is homogeneous and completely covers all fields equally. Center the x-ray beam on the center field. Collimate the x-ray beam so that it completely covers all three fields but does not extend beyond the limits of the phantom.

Chamber Gain Adjustment (R12):

Typically, the chamber gain adjustment is the only adjustment needed when installing an ICX series ion chamber. Use the chamber gain adjustment to match the overall chamber sensitivity to that of the other stationary chambers connected to the system. Note that the chamber gain adjustment is a multi-turn potentiometer. A counter-clockwise adjustment to the chamber gain potentiometer will increase the sensitivity of the chamber, causing the length of the exposure (mAs) to decrease.

Make exposures and process the films. Adjust the chamber gain for the desired optical density. Make the chamber gain adjustment for each stationary chamber being installed.

Balance Check:

Using the Expos-AID AEC post-exposure mAs display or other calibrated mAs meter check the individual fields to see that they are balanced, that is, that they produce the same mAs reading. If mAs readings are not stable from exposure to exposure for an individual field, then it will be necessary to expose films and make these adjustments based upon optical density.

The individual gain potentiometers (R15, R25 and R32) correspond to ion chamber fields 2, 1 and 3 respectively. Refer to the listings on page 3 to determine the field arrangement for each chamber model. If necessary, adjust the individual gain potentiometers to balance the outputs to give the same mAs reading for each field. Note that individual gain adjustments are multi-turn potentiometers. A clockwise adjustment to a gain potentiometer will increase the sensitivity of a field, causing the length of the exposure (mAs) to decrease.

Drift Adjustments:

The Drift Adjustments (R20, R29 and R37) are preset at the factory for a rate $< 30\text{mV}/10$ seconds. They are not to be adjusted on site. If the drift adjustments are incorrect return the ion chamber to the factory for recalibration.

Ionization Chamber Pin outs:

60917F PRE-AMP BOARD PIN NUMBER	60917F PRE-AMP CHASSIS WIRE COLOR	FUNCTION	9 PIN SUB-D PIN NUMBER	ION CHAMBER CABLE WIRE COLOR
N/C	N/C	NO CONNECTION	1	BLACK
3	WHITE	FIELD 2 SELECT	2	BROWN
2	BLACK	FIELD 1 SELECT	3	RED
4	BLUE	RESET	4	ORANGE
5	VIOLET	OUTPUT	5	YELLOW
6	RED	FIELD 3 SELECT	6	GREEN
7	YELLOW	-15VDC	7	BLUE
8	ORANGE	+15VDC	8	VIOLET
9	GREEN	GROUND	9	WHITE/SHIELD*

*Shield is attached only on the ion chamber (female connector) end of the cable.

Acceptable Power Supply Ranges for 60917F Pre-amp:

Supply Voltage	Measurement Point	Acceptable Range	
(Pos. Input Supply Voltage) +12VDC	60917F pin 8	From +11.4VDC to +12.6VDC	
(Neg. Input Supply Voltage) -12VDC	60917F pin 7	From -11.4VDC to -12.6VDC	
(Regulated on board) +5VDC	60917F C9 (positive lead)	From +4.7VDC to +5.3VDC	
(Regulated on board) -5VDC	60917F C8 (negative lead)	From -4.7VDC to -5.3VDC	
Internal Bias Voltage Regulated on board	+75VDC	60917F C3 at the cathode of D4	From +65VDC to +85VDC
	Or +150VDC	60917P C3 at the cathode of D4	From +135VDC to +155VDC

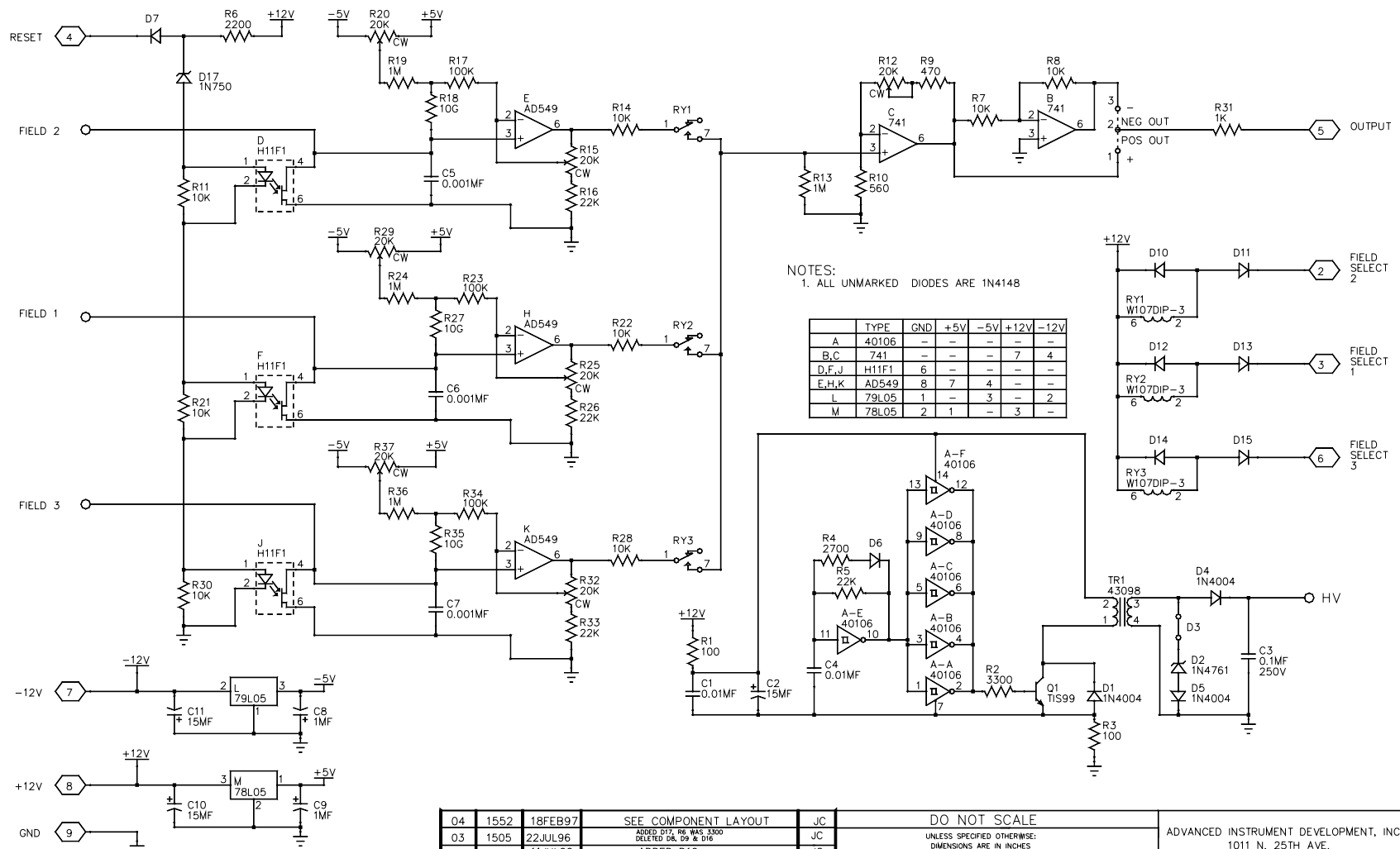

NOTES:
1. ALL UNMARKED DIODES ARE 1N4148

	TYPE	GND	+5V	-5V	+12V	-12V
A	40106	-	-	-	-	-
B,C	741	-	-	-	7	4
D,E,J	H11F1	6	-	-	-	-
E,H,K	AD549	8	7	4	-	-
L	79L05	1	-	3	-	2
M	78L05	2	1	-	3	-

REV	ECN NO.	DATE	REVISIONS	BY	THIS DRAWING REPRESENTS PROPRIETARY AND CONFIDENTIAL INFORMATION ORIGINATED BY ADVANCED INSTRUMENT DEVELOPMENT, INC. AND WHICH SHALL NOT BE DISCLOSED OR UTILIZED IN ANY MANNER DETRIMENTAL TO THE COMPANY'S BUSINESS.
04	1552	18FEB97	SEE COMPONENT LAYOUT	JC	DO NOT SCALE UNLESS SPECIFIED OTHERWISE: DIMENSIONS ARE IN INCHES FRACTIONS +/- 1/84 DEC. +/- 0.010 ANGLES +/- 1 DEGREE
03	1505	22JUL96	ADDED D17, R6 WAS 330K DELETED D8, D9 & D16	JC	
03	1502	11JUL96	ADDED D16	JC	SCALE NONE DRAWN BY J.GREEN DATE 17NOV80 MATERIAL CHECKED BY FINISH APPROVED BY
02	1448	21DEC95	SEE COMPONENT LAYOUT	JC	
01	1446	30SEP94	SEE COMPONENT LAYOUT	JC	ADVANCED INSTRUMENT DEVELOPMENT, INC. 1011 N. 25TH AVE. MELROSE PARK, IL 60160 PRE-AMP BOARD
00	1220	7MAR94	HARNESS 73467 WAS CONNECTOR 47107	BRP	
F	1011	9AUG91	D2 AND 3 WERE 1N4764	RT	USED ON
					ICX SERIES
					NEXT ASSY.
					DRAWING NO. 60917F
					REV 04

FOR FACTORY CALIBRATION ONLY.

