

Advanced Instrument Development, Inc.
2545 Curtiss St.
Downers Grove, IL 60515 U.S.A.

Phone: (630) 271-9729

www.aidxray.com

Fax: (630) 271-9995

Model ICX110, ICX210 and ICX410
Three-field Ionization Chamber
Calibration Procedure for Pre-Amplifier board 61135L

The following adjustments apply to the calibration of a 61135L pre-amplifier board for a stationary 3-field ion chamber, e.g. for chest or table use.

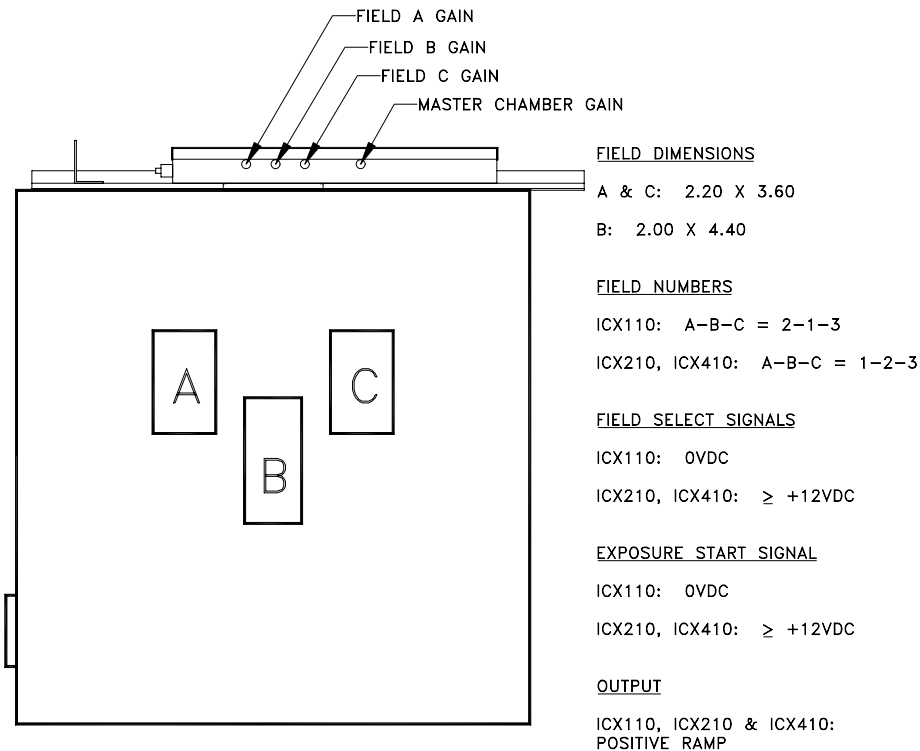

WARNING:

- This service manual is available in English only.
- If a customer's service provider requires a language other than English, it is the customer's responsibility to provide translation services.
- Do not attempt to service the equipment unless this service manual has been consulted and is understood.
- Failure to heed this warning may result in injury to the service provider, operator or patient from electric shock mechanical or other hazards.

This document represents proprietary information originated by Advanced Instrument Development, Inc. and which shall not be disclosed or utilized in any manner detrimental to the company's business.

Advanced Instrument Development, Inc.
2545 Curtiss St.
Downers Grove, IL 60515 U.S.A.

Phone: (630) 271-9729

www.aidxray.com

Fax: (630) 271-9995

The procedure assumes that the installation of the Automatic Exposure Control (AEC) is complete and that the AEC and x-ray generator are in proper working condition. After making the necessary interconnections between the ion chamber and the AEC, power up the system.

Calibration/Test Set Up:

Select the center field of the ion chamber. Set the generator for 100 kVp and maximum backup time. For 100 kVp use 8 to 10 inches of water or plastic for a phantom. Metals such as copper, aluminum or lead are not suitable for use as phantoms. Make sure the phantom is homogeneous and completely covers all fields equally. Center the x-ray beam on the center field. Collimate the x-ray beam so that it completely covers all three fields but does not extend beyond the limits of the phantom.

Master Gain Adjustment (61135L R22):

Typically, the master gain adjustment is the only adjustment needed when installing an ICX series ion chamber. Use the master gain adjustment to match the overall chamber sensitivity to that of the other stationary chambers connected to the system. Note that the master gain adjustment is a multi-turn potentiometer. A clockwise adjustment to the master gain potentiometer will increase the sensitivity of the chamber, causing the length of the exposure (mAs) to decrease.

Make exposures and process the films. Adjust the master gain for the desired optical density. Make the master gain adjustment for each stationary chamber being installed.

Balance Check:

Using the Expos-AID AEC post-exposure mAs display or other calibrated mAs meter check the individual fields to see that they are balanced, that is, that they produce the same mAs reading. If mAs readings are not stable from exposure to exposure for an individual field, then it will be necessary to expose films and make these adjustments based upon optical density.

If necessary, adjust the individual gain potentiometers to balance the outputs to give the same mAs reading for each field. Note that individual gain adjustments are multi-turn potentiometers. A clockwise adjustment to a gain potentiometer will increase the sensitivity of a field, causing the length of the exposure (mAs) to decrease.

Advanced Instrument Development, Inc.
 2545 Curtiss St.
 Downers Grove, IL 60515 U.S.A.

Phone: (630) 271-9729

www.aidxray.com

Fax: (630) 271-9995

on Chamber Pin Outs:

61135L PIN OUTS	WIRE COLOR	FUNCTION	14-PIN AMP M-SERIES CONNECTOR
1	NONE	NO CONNECTION	NONE
2	YELLOW	FIELD 2 SELECT	D
3	VIOLET	FIELD 1 SELECT	H
4	WHITE	OUTPUT	B
5	GRAY	RESET (START INTEGRATING)	J
6	BROWN	FIELD 3 SELECT	A
7	BLUE	-15VDC	F
8	ORANGE	+15VDC	C
9	BLACK	GND	L
G2	BLACK	SHIELD	K

Acceptable Power Supply Ranges for 61135L Pre-amp:

Supply Voltage	Measurement Point	Acceptable Range
+15VDC Input Supply Voltage	61135L pin 8	+11.4VDC to +15.75VDC
-15VDC Input Supply Voltage	61135L pin 7	-11.4VDC to -15.75VDC
+5VDC Regulated on board	61135L C12 (positive lead)	+4.7VDC to +5.3VDC
+75VDC Internal Bias Voltage	61135L HV1 or HV2	+65.0VDC to +85.0VDC

Advanced Instrument Development, Inc.
2545 Curtiss St.
Downers Grove, IL 60515 U.S.A.

Phone: (630) 271-9729

www.aidxray.com

Fax: (630) 271-9995

Ionization Chamber Inputs and Output:

Signal	Jumper	Comments
Positive Supply Voltage Range	None	+11.4VDC to +15.75VDC less than 85 mA.
Negative Supply Voltage Range	None	-11.4VDC to -15.75VDC less than 15 mA.
Low-Active Reset (Start Integrating)	W1 = 1-2 & 3-4	Pulling this line to ground (≤ 8 VDC) beginning at exposure start and lasting for the entire duration of the exposure allows the integrator to operate.
High-Active Reset (Start Integrating)	W1 = 2-3 & 4-5	Pulling this high (≥ 4 VDC) beginning at exposure start and lasting for the entire duration of the exposure allows the integrator to operate.
Low-active Field Selects	W2, W3 and W4 = 1-2 & 3-4	Low-active: Pulling the field select lines to ground (0VDC) will select the field.
High-active Field Selects	W2, W3 and W4 = 2-3 & 4-5	High-active: Driving the field select lines high (+12VDC to +24VDC) will select the field.
Field Configuration A-B-C = 1-2-3	W5 = 1-3 & 2-4 and W6 = 1-2 & 3-4	Field selects 1, 2 and 3 select left (A), center (B) and right (C), respectively, as viewed from the x-ray tube-side of the ion chamber.
Field Configuration A-B-C = 2-1-3	W5 = 1-2 & 3-4 and W6 = 1-2 & 3-4	Field selects 2, 1 and 3 select left (A), center (B) and right (C), respectively, as viewed from the x-ray tube-side of the ion chamber.
Field Configuration A-B-C = 3-1-2	W5 = 1-2 & 3-4 and W6 = 1-3 & 2-4	Field selects 3, 1 and 2 select left (A), center (B) and right (C), respectively, as viewed from the x-ray tube-side of the ion chamber.
Field Configuration A-B-C = 3-2-1	W5 = 1-3 & 2-4 and W6 = 1-3 & 2-4	Field selects 3, 2 and 1 select left (A), center (B) and right (C), respectively, as viewed from the x-ray tube-side of the ion chamber.
Negative Output	W7 = 1-2	Time integrated signal ramping from 0VDC to a maximum of at least 80% of the supply voltage (-9.6VDC for -12VDC supply). The slope of this signal is directly proportional to the amount of x-ray flux received.
Positive Output	W7 = 2-3	Time integrated signal ramping from 0VDC to a maximum of at least 80% of the supply voltage (+9.6VDC for +12VDC supply). The slope of this signal is directly proportional to the amount of x-ray flux received.

Advanced Instrument Development, Inc.
2545 Curtiss St.
Downers Grove, IL 60515 U.S.A.

Phone: (630) 271-9729

www.aidxray.com

Fax: (630) 271-9995

Specific Configurations:

Unless specified otherwise, ICX ion chambers are delivered with an AID compatible jumper configuration. AID compatible means that the input and output signals will interface with Advanced Instrument Development, Inc's Expos-AID™ Automatic Exposure Control. This same configuration will also interface with Acoma, Control-X, CPI, Del Medical (Gendex), Electromed (EMD, Triton), OEC, Quantum Medical Imaging, Sedecal (Innerscan), Summit Industries, etc.

Model ICX110

AID Compatible jumper configuration:

Jumper	Position	Function
61135L W1	1-2 & 3-4	low-active reset
61135L W2, W3 and W4	1-2 & 3-4	low-active field select
61135L W5 and 61135L W6	1-2 & 3-4 and 1-2 & 3-4	A-B-C = 2-1-3
61135L W7	2-3	positive output signal

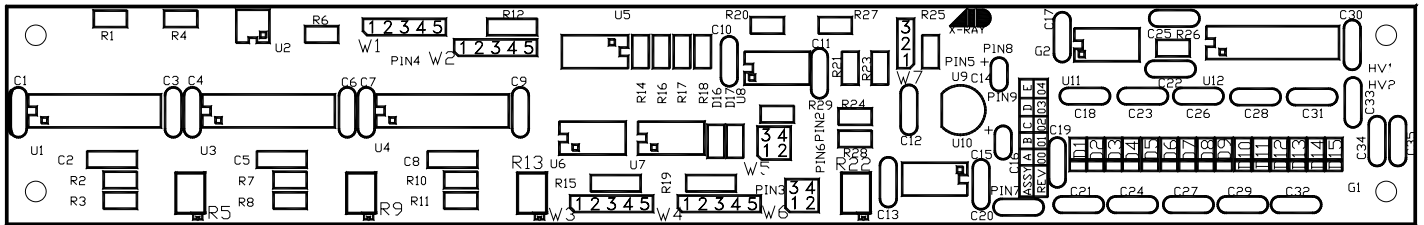

Model ICX210 and ICX410

GE, Fischer, Varian Compatible jumper configuration:

Jumper	Position	Function
61135L W1	2-3 & 4-5	high-active reset
61135L W2, W3 and W4	2-3 & 4-5	high-active field select
61135L W5 and 61135L W6	1-3 & 2-4 and 1-2 & 3-4	A-B-C = 1-2-3
61135L W7	2-3	positive output signal

Advanced Instrument Development, Inc.
 2545 Curtiss St.
 Downers Grove, IL 60515 U.S.A.

Phone: (630) 271-9729

www.aidxray.com

Fax: (630) 271-9995

Model ICX510

Trex - Bennett Compatible jumper configuration:

Jumper	Position	Function
61135L W1	1-2 & 3-4	low-active reset
61135L W2, W3 and W4	1-2 & 3-4	low-active field select
61135L W5 and 61135L W6	1-3 & 2-4 and 1-2 & 3-4	A-B-C = 1-2-3
61135L W7	1-2	negative output signal

Model ICX610

Trex - Continental, Keithley, Ratheon, Xonics Compatible jumper configuration:

Jumper	Position	Function
61135L W1	1-2 & 3-4	low-active reset
61135L W2, W3 and W4	1-2 & 3-4	low-active field select
61135L W5 and 61135L W6	1-3 & 2-4 and 1-2 & 3-4	A-B-C = 1-2-3
61135L W7	2-3	positive output signal

Model ICX810

Picker Compatible jumper configuration:

Jumper	Position	Function
61135L W1	1-2 & 3-4	low-active reset
61135L W2, W3 and W4	1-2 & 3-4	low-active field select
61135L W5 and 61135L W6	1-2 & 3-4 and 1-2 & 3-4	A-B-C = 2-1-3
61135L W7	1-2	negative output signal

Model ICX110R

GTR Labs Compatible jumper configuration:

Jumper	Position	Function
61135A W1	1-2 & 3-4	low-active reset
61135A W2, W3 and W4	1-2 & 3-4	low-active field select
61135A W5 and 61135A W6	1-2 & 3-4 and 1-3 & 2-4	A-B-C = 3-1-2 (= GTR Labs fields 1-2-3)
61135A W7	2-3	positive output signal

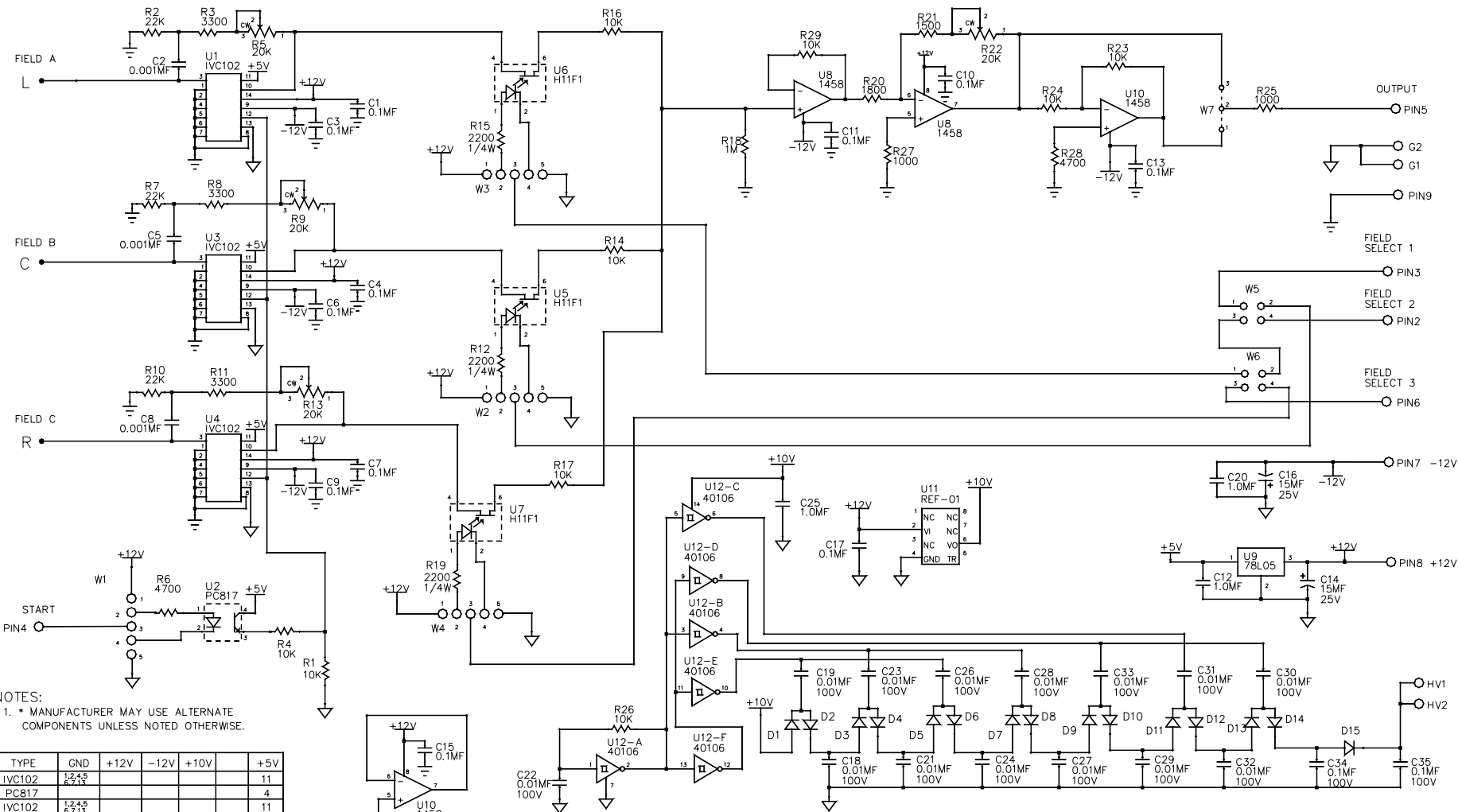

NOTES:
 1. * MANUFACTURER MAY USE ALTERNATE COMPONENTS UNLESS NOTED OTHERWISE.

	TYPE	GND	+12V	-12V	+10V	+5V
U1	IVC102	1,2,4,5				11
U2	PC817					4
U3	IVC102	1,2,4,5				11
U4	IVC102	1,2,4,5				11
U5	H11F1					
U6	H11F1					
U7	H11F1					
U8	1458	5	8	4		
U9	78L05	2	3			1
U10	1458	3,5	8	4		
U11	REF-01	4	2		6	
U12	40106	7			14	

				DO NOT SCALE			ADVANCED INSTRUMENT DEVELOPMENT, INC. 1011 N. 25TH AVE. MELROSE PARK, IL. 60160 				
				UNLESS SPECIFIED OTHERWISE; DIMENSIONS ARE IN INCHES. FRACTIONS DECIMALS ANGLES							
01	2047	03MAY02	SEE LAYOUT	TRW	SCALE	DRAWN BY	DATE	LOW-LEAKAGE, GEMS-GAIN 3-FIELD PRE-AMP BD SIDE-TURN POTS			
00	2021	12NOV01	SAME AS 61135X EXCEPT: R5, R9, R13 & R22 = 20K S-T POTS R20=1800, R21=1500, R27=1000	BRP	MATERIAL	CHECKED BY	27DEC01				
					FINISH	APPROVED BY					
REV.	ECN NO.	DATE	REVISIONS	BY	THIS DRAWING REPRESENTS PROPRIETARY AND CONFIDENTIAL INFORMATION ORIGINATED BY ADVANCED INSTRUMENT DEVELOPMENT, INC. AND WHICH SHALL NOT BE DISCLOSED OR UTILIZED IN ANY MANNER DETRIMENTAL TO THE COMPANY'S BUSINESS.			USED ON ICX SERIES	NEXT ASSY.	DRAWING NO. 61135L	REV. 01