

Three-field Ionization Chamber
Calibration Procedure for Pre-Amplifier board 61084A

The following adjustments apply to the calibration of a 61084A pre-amplifier board for a stationary 3-field ion chamber, e.g. for chest or table use.

Note: This procedure is also valid for 61084C and 61084D pre-amp assemblies.

Pre-amp Assembly	Description	Difference from 61084A
61084A	3-Field Philips Compatible Pre-amp, Standard Gain	None
61084C	3-Field Philips Compatible Pre-amp, Wide Field-Gain Range, High-Master-Gain	R7, R12, R14 & R20 = 100K ohm
61084D	3-Field Philips Compatible Pre-amp, High-Master-Gain	R15 = 10K ohm R27 = 2200 ohm

WARNING:

- This service manual is available in English only.
- If a customer's service provider requires a language other than English, it is the customer's responsibility to provide translation services.
- Do not attempt to service the equipment unless this service manual has been consulted and is understood.
- Failure to heed this warning may result in injury to the service provider, operator or patient from electric shock and mechanical or other hazards.

This document represents proprietary information originated by Advanced Instrument Development, Inc. and which shall not be disclosed or utilized in any manner detrimental to the company's business.

The procedure assumes that the installation of the Automatic Exposure Control (AEC) is complete and that the AEC and x-ray generator are in proper working condition. After making the necessary interconnections between the ion chamber and the AEC, power up the system.

Calibration/Test Set Up:

Select the center field of the ion chamber. Set the generator for 100 kVp and maximum backup time. For 100 kVp use 8 to 10 inches of water or plastic for a phantom. Metals such as copper, aluminum or lead are not suitable for use as phantoms. Make sure the phantom is homogeneous and completely covers all fields equally. Center the x-ray beam on the center field. Collimate the x-ray beam so that it completely covers all three fields but does not extend beyond the limits of the phantom.

Adjustment Potentiometers:

All necessary adjustment potentiometers are accessible through the pre-amp chassis cover. There is no need to open the pre-amp cover during normal calibration procedures.

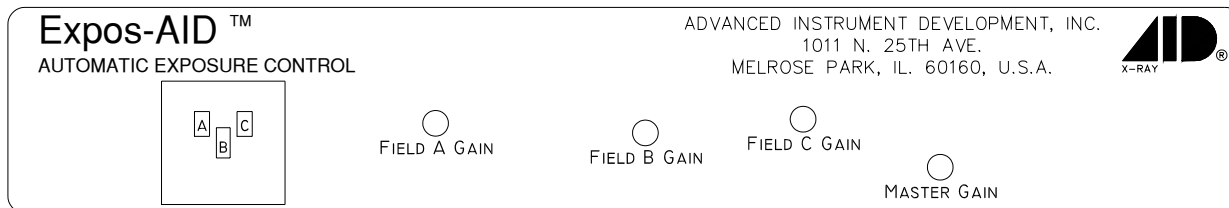

Master Gain Adjustment (R20):

Typically, the master gain adjustment is the only adjustment needed when installing an ICX series ion chamber. Use the master gain adjustment to match the overall chamber sensitivity to that of the other stationary chambers connected to the system. Note that the master gain adjustment is a multi-turn potentiometer. A clockwise adjustment to the master gain potentiometer will increase the sensitivity of the chamber, causing the length of the exposure (mAs) to decrease.

Make exposures and process the films. Adjust the master gain for the desired optical density. Make the master gain adjustment for each stationary chamber being installed.

Some x-ray generators require a significant increase in the sensitivity of the ion chamber. Shunt jumper W2 may be selected to accommodate these systems. Selection of W2 will boost the ion chamber gain by a factor of about 4X.

Balance Check:

Using the Expos-AID AEC post-exposure mAs display or other calibrated mAs meter check the individual fields to see that they are balanced, that is, that they produce the same mAs reading. If mAs readings are not stable from exposure to exposure for an individual field, then it will be necessary to expose films and make these adjustments based upon optical density.

The individual gain potentiometers (R7, R12 and R14) correspond to the Field 2, Field 1 and Field 3 ion chamber fields, respectively. If necessary, adjust the individual gain potentiometers to balance the outputs to give the same mAs reading for each field. Note that individual gain adjustments are multi-turn potentiometers. A clockwise adjustment to a gain potentiometer will increase the sensitivity of a field, causing the length of the exposure (mAs) to decrease.

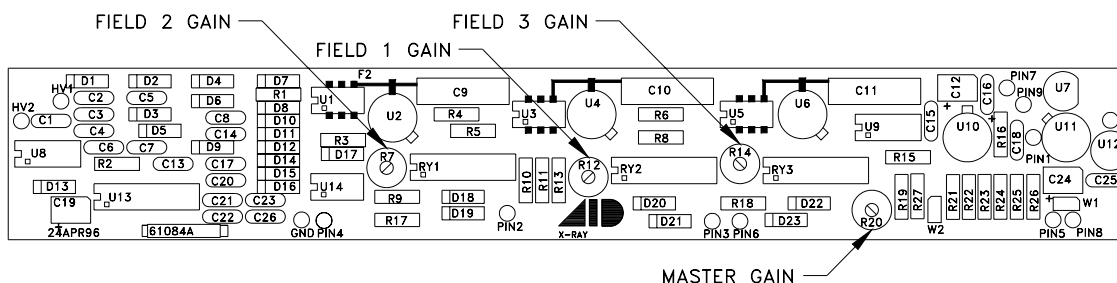

Ion Chamber Pin Outs:

61084A Pin No.	9- or 15-Pin Sub-D Connector	12-Pin Connector	14-Pin Amp Connector	Function
1	1	105	L	+45VDC (+45VCH)
2	2	101	A	Field 2 Select (FDLCH)
3	3	102	D	Field 1 Select (FDCCH)
4	4	104	E	Start Integrating (RELCH)
5	5	107	R	Output (SIGNCH)
6	6	103	H	Field 3 Select (FDRCH)
7	7	106	P	-15 to -24VDC (-15VXG)
8	8	109	N	0VDC (0V RELAYS)
9	9	108	J	GND (0VXG/0VRF)
---	10-15	100, 110 & 111	B,C,F,K,M	No Connection

12 PIN CONNECTOR

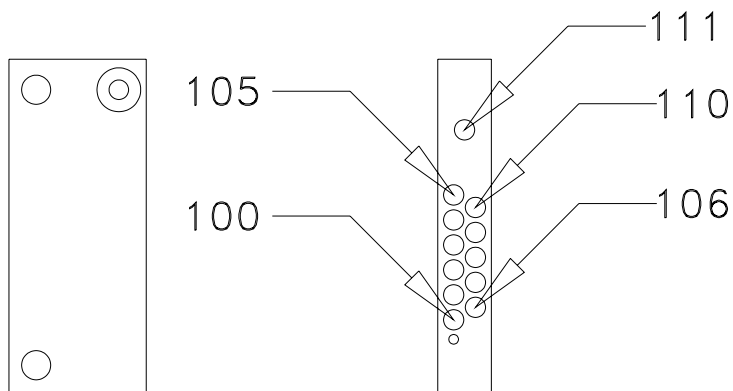

Acceptable Power Supply Ranges for 61084A Pre-amp:

Supply Voltage	Measurement Point	Acceptable Range
+45VDC Pos. Input Supply Voltage	61084A pin 1	From +43VDC to +49VDC
-24VDC Neg. Input Supply Voltage	61084A pin 7	From -22VDC to -29VDC
+5VDC Regulated on board	61084A C25 (positive lead)	From +4.7VDC to +5.3VDC
-5VDC Regulated on board	61084A C16 (negative lead)	From -4.7VDC to -5.3VDC
+75VDC Internal Bias Voltage Regulated on board	61084A C1 at the cathode of D1	From +65VDC to +85VDC

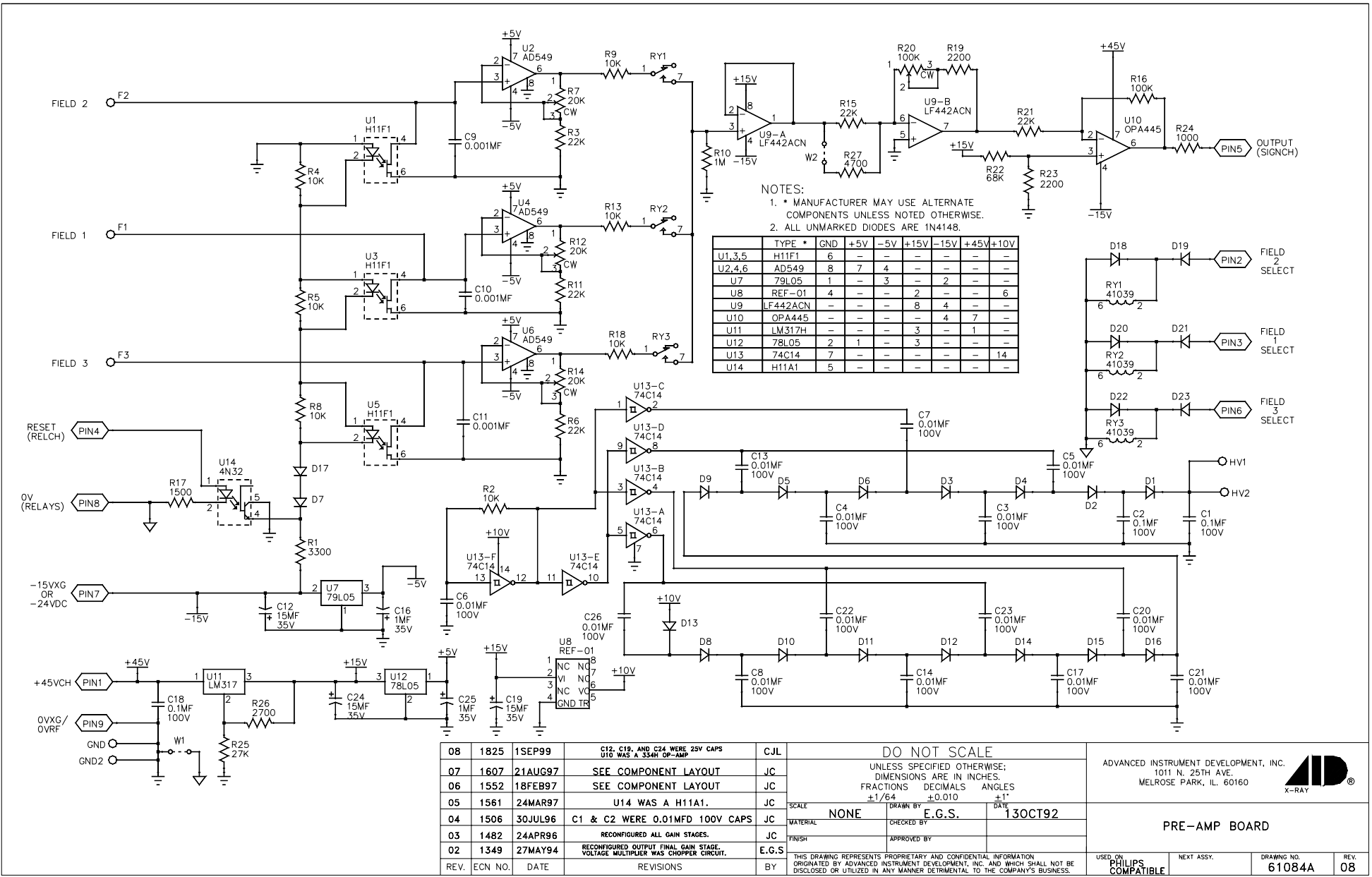

08	1825	1SEP99	C12, C19, AND C24 WERE 25V CAPS U10 WAS A 354H OP-AMP	C.J.L.
07	1607	21AUG97	SEE COMPONENT LAYOUT	J.C.
06	1552	18FEB97	SEE COMPONENT LAYOUT	J.C.
05	1561	24MAR97	U14 WAS A H11A1.	J.C.
04	1506	30JUL96	C1 & C2 WERE 0.01MFD 100V CAPS	J.C.
03	1482	24APR96	RECONFIGURED ALL GAIN STAGES.	J.C.
02	1349	27MAY94	RECONFIGURED OUTPUT FINAL GAIN STAGE. VOLTAGE MULTIPLIER WAS CHOPPER CIRCUIT.	E.G.S.
REV.	ECN NO.	DATE	REVISIONS	BY

DO NOT SCALE		
UNLESS SPECIFIED OTHERWISE: DIMENSIONS ARE IN INCHES.		
FRACTIONS	DECIMALS	ANGLES
+1/64	+0.010	+1°
SCALE	DRAWN BY	DATE
NONE	E.G.S.	13OCT92
MATERIAL	CHECKED BY	
	APPROVED BY	
THIS DRAWING REPRESENTS PROPRIETARY AND CONFIDENTIAL INFORMATION ORIGINATED BY ADVANCED INSTRUMENT DEVELOPMENT, INC. AND WHICH SHALL NOT BE DISCLOSED OR UTILIZED IN ANY MANNER DETRIMENTAL TO THE COMPANY'S BUSINESS.		

ADVANCED INSTRUMENT DEVELOPMENT, INC. 1011 N. 25TH AVE. MELROSE PARK, IL. 60160		
PRE-AMP BOARD		
USED ON PHILIPS COMPATIBLE	NEXT ASSY.	DRAWING NO. 61084A
		REV. 08