

# Mobil-AID®

Automatic Exposure Control  
AID Model D1323  
for the  
Picker Meteor

## 1.0 INTRODUCTION

The Mobil-AID Automatic Exposure Control (AEC) is an important accessory for the field of mobile radiography. It greatly simplifies the use of systems such as the Picker Meteor mobile x-ray generator by automatically controlling the exposure required for every radiograph, compensating for variations in parameters such as:

- Patient anatomy and size
- Source-to-image distance (SID)
- kVp-dependent response of screen-film combinations

The operator is required only to select a reasonable kVp for the anatomy involved and position the circular ionization chamber field or fields of the Mobil-AID paddle **behind the film cassette in line with the anatomy of principle interest. The Mobil-AID AEC does the rest, automatically determining the exposure time for the precise milliampere-seconds (mAs) required to give excellent diagnostic radiographs. The results are:**

- Reduction in number of x-ray retakes, along with their cost and inconvenience.
- Reduction in patient and operator radiation required to produce good films.
- Films that are not only consistently diagnostic, but that are uniformly exposed by all operators on all shifts and on all AEC equipped generators.

There are a number of differences between the Mobil-AID AEC and other "photo-timer" AEC systems used with stationary x-ray systems. The ion chamber under mobile operating conditions cannot be protected from damage as it is in a table or wall installation. Rather it must be securely mounted inside a very sturdy paddle for rough handling in hospital beds, emergency carts, etc. Since this paddle is so sturdy, it obviously cannot be used in front of the film cassette as are the typical entrance-type ion chambers. Therefore in order not to be seen on the films, the paddle is placed **behind the film cassette and operates as an exit-type ion chamber.**

Some of the detailed features of the Mobil-AID AEC are:

- Push button selection of either of two screen-film combinations chosen for calibration into the system at the time of installation.
- Switch adjustment for film Optical Density variations to suit individual preferences of darker or lighter films.
- Push button selection of either grid or no grid operation.
- Push button selection of one or both of the ion chamber fields.
- Exposure termination indicators to assure the operator of the proper functioning of the AEC.

## 2.0 OPERATING INSTRUCTIONS

### 2.0 OPERATING INSTRUCTIONS

1. Turn on the Picker Meteor.<sup>1</sup>
2. Turn on Mobil-AID AEC.
3. Select an appropriate SID for the procedure and align the tube head properly.
4. Position the film cassette.
5. **Select a reasonable kVp for the anatomy involved.**
6. Select a backup mAs setting that will not interfere with AEC operation (approximately three to four times the mAs you would select for a manual technique.)
7. Place the paddle **behind the film cassette, aligning the circular ionization chamber field(s) with the principal anatomy to be radiographed.**
8. Make the exposure. The Mobil-AID AEC will terminate the exposure when the film has been exposed to the proper Optical Density.



#### 2.1 Paddle Alignment

Paddle alignment may be facilitated by first holding the paddle in front of the patient with ion-chamber Field One over the desired position, and then noting how the centimeter marks on the paddle line up with reference to the edge of the cassette (avoid parallax). Then slip the paddle **behind the cassette until these measuring marks are at its edge.**

For example, when shooting a normal chest in the anterior- posterior projection, place the ion-chamber field behind the right lung. Or, when shooting a lateral skull align the ion-chamber field with the skull. Or, to follow the course of pneumonia in the left lung with a series of radiographs, always align ion-chamber Field One with the fluid in that particular lung. Do not align the ion-chamber field with anatomy other than that of principle interest. For example, do not align with the spine to see the lung and do not align with the lung to see the spine as this would obviously not produce the optimum exposures.

The paddle has two fields, which can also be used for normal chest shots, Field One behind one lung and Field Two behind the other lung. In this operating mode, paddle positioning is simplified. As usual, center the film cassette behind the patient. Note the tactile finger positions on the paddle and use the appropriate set for the cassette orientation (see Figure 2.1.) Align the paddle to the correct height of the patient's lung, and then slip the paddle behind the film cassette to the point where the fingers in the tactile position touch the edge of the cassette.

---

<sup>1</sup>Refer to the x-ray generator operator's guide for proper operation.

## 2.0 OPERATING INSTRUCTIONS

Figure 2.1

Mobil-AID AEC Paddle

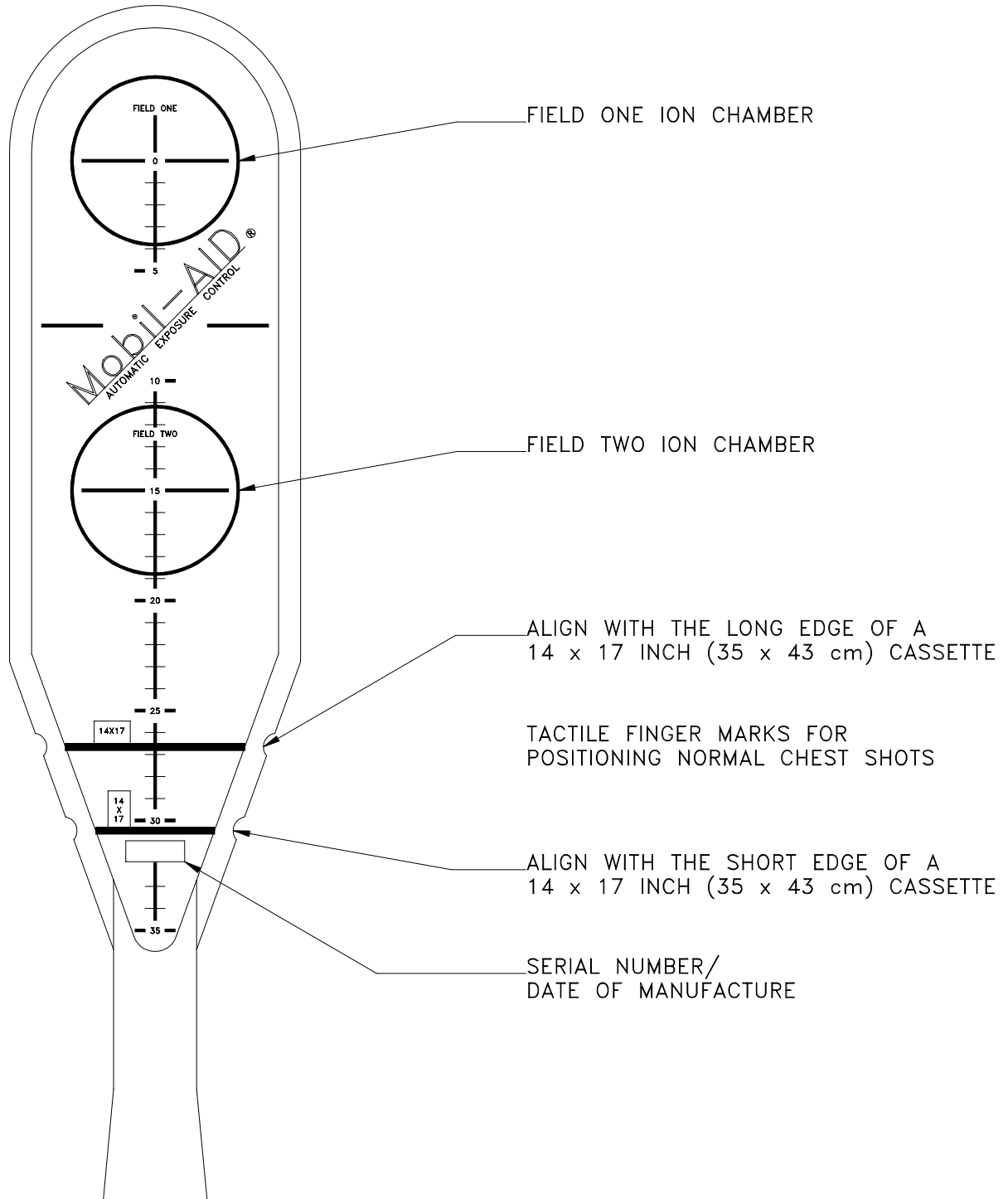

## 2.0 OPERATING INSTRUCTIONS

### 2.2 Push Button Assembly - Controls and Indicators

Figure 2.2

Push Button Assembly - Controls and Indicators

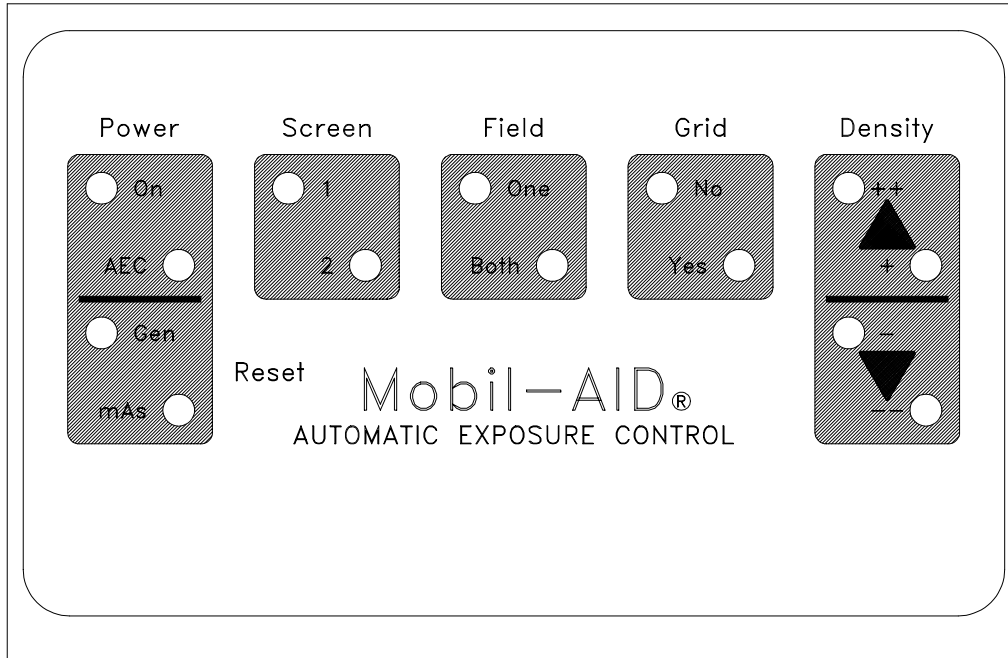

- **AEC Power On/Off - Controls power supplied to the Mobil-AID AEC circuitry. If Off, all functions of the AEC circuitry are disabled and the x-ray generator may be operated manually. The On lamp indicates that AEC operation is selected. A flashing On lamp indicates that the Mobil-AID AEC paddle is not properly connected.**
- **Screen Selection - Selects Screen 1 or Screen 2. These numbers simply refer to two screen-film combinations that have been calibrated into a particular system at the owner's request at the time of installation. Screen lamps indicate which screen-film combination has been selected. The default state when the AEC is turned on is Screen 1. If the system is calibrated for only one screen, screen selection can be disabled.**
- **Field Selection - Selects Field One or both fields. Field lamps indicate the selection. The default state when the AEC is turned on is Field One.**
- **Grid Selection - This provides the proper compensation in Optical Density for the use of either a grid (yes) or no grid (no) with both of the screen-film combinations. The default state when the AEC is turned on is no grid (no). If the system is calibrated for only no grid, grid selection (yes) can be disabled.**
- **Reset - Required to permit another radiograph only if an exposure has not been properly terminated and indicated on the panel ("AEC"). If an exposure has been**

## 2.0 OPERATING INSTRUCTIONS

terminated by the backup generator setting ("GEN"), or if the maximum allowable exposure time (3.2 seconds) has been sensed ("mAs"), the Reset control must be manually operated to allow additional exposures. The need to activate the RESET control should be interpreted by the operator as a potential radiation safety warning.

- **Exposure Termination Indicators**

**AEC LED (green) - Normal exposure termination when using the Mobil-AID AEC will momentarily light the AEC LED.** Normal exposure termination using the Mobil-AID AEC will also result in a post-exposure display of the actual mAs on the generator's LCD display.

**GEN LED (red) - Exposure termination by the x-ray generator.** The exposure reached the backup mAs limit set by the operator on the x-ray generator.

**mAs LED (red) - Exposure termination by Mobil-AID AEC after 3.2 seconds. In this unlikely event, no further exposures should be attempted until the cause of the default termination is determined and corrected.**

- **Density Control**

No lamp indication, Normal film Optical Density setting. This is the default state when the AEC is turned on.

Density Up - Pressing the up arrow increases the film optical density one step at a time. The corresponding LED indicates the selected density level. The "+" LED and the "+ +" LED indicate 125% and 150% of the neutral density, respectively.

Density Down - Pressing the down arrow decreases the film optical density one step at a time. The corresponding LED indicates the selected density level. The "-" LED and the "--" LED indicate 75% and 50% of the neutral density, respectively.

This is routinely set at Normal where the system was calibrated for proper film Optical Density. It is used to satisfy particular preferences of individual radiologists for darker or lighter than normal films or in cases where special circumstances may require other than normal Optical Density films.

## 2.0 OPERATING INSTRUCTIONS

### 2.3 Generator-Terminated Exposure

If the **GEN** LED lights after an exposure, then the exposure has been terminated by the x- ray generator -- not the AEC!

Causes: Either the generator back-up time (related to mAs setpoint) is too short, the ionization chamber is not in position in the x-ray beam or the operator released the x-ray switch before AEC termination. Determine and correct the cause of the improper exposure termination; then press the "Reset" button on the push button assembly to permit another exposure.

### 2.4 AEC Backup Timer - Terminated Exposure

If the **mAs** LED lights after an exposure, the exposure was terminated by the Mobil-AID AEC built-in 3.2 second default limit.

Causes: This unlikely event indicates the possibility of improper positioning of the paddle, or a service problem with either the x-ray generator or the Mobil-AID AEC. No further exposures should be attempted until the cause of the default termination is determined and corrected.

### 2.5 Routine Care and Maintenance

- **Do clean the paddle with a weak detergent cleaning solution. Turn off the x-ray generator key switch when cleaning the paddle.**
- **Do inspect the paddle cable periodically for evidence of damage (e.g. paddle cable run over by the generator wheels, paddle cable wrapped around the vertical column of the generator, etc.).**
  - **Do not use the paddle as a lever to turn or lift the patient.**
  - **Do not sterilize the paddle in an autoclave. If desired, the paddle can be encased in a sterile plastic bag during the x-ray examination.**
  - **Do not attempt to open the paddle. It is sealed liquid tight and is therefore not field serviceable. The manufacturer cannot be responsible for units that show evidence of tampering.**

### 3.0 SPECIFICATIONS

#### 3.0 SPECIFICATIONS

The following specifications apply to performance with the Picker Meteor mobile x-ray generator:

#### 3.1 System Performance

##### **kVp Range/Optical Density (OD) Tracking**

kVp Range	Phantom Thickness cm (inches)	Optical Density Variation +OD from 1.20
50-65	13 (5)	0.25
65-80	18 (7)	0.15
80-95	20 (8)	0.15
95-110	23 (9)	0.15
110-125	25 (10)	0.25

##### **Temporal Characteristics**

Response time	+1.0ms
Exposure termination anticipation	effective during first 15ms of exposure.
Default termination	3.2 seconds

##### **Screen-film Speed**

Generally, combinations from approximately 50 to 600 may be accommodated. Variations in cassettes make it difficult to be more specific, but even greater range may be possible.

##### **kVp Compensation**

kVp compensation adjustments are made at five kVp calibration set points (50, 65, 80, 95, and 110).

#### 3.2 Paddle/Ion Chamber

Input voltages	+12VDC and -12VDC
Sensitivity (nominal)	> 40V/second/mR at 80kVp
Maximum output	8.5VDC
Drift & noise	< 30mV/10 seconds
Ion chamber field size	Nominal 7.6cm (3 inch) diameter by 1 cm (0.38 inch) thick
Number of ion chamber fields	2
Ion chamber potential	75VDC +5VDC (internally generated)
Reproducibility	< 0.05 coefficient of variation
Mechanical scale	Paddle position scale in centimeters

## 3.0 SPECIFICATIONS

### 3.3 Push button Assembly

The following controls and indicators are located on the push button assembly:

#### **On/Off Selection**

Controls power supplied to the Mobil-AID AEC circuitry. The On lamp indicates that AEC operation is selected.

#### **Paddle Interlock**

If the paddle or paddle cable is disconnected or the paddle cable is cut, the On lamp will flash indicating that the AEC is not ready for operation. This condition will also disable the Picker Meteor until the problem is corrected or the AEC is turned off.

#### **Screen-film Selection**

Selects either one of the two screen-film combinations that have been chosen for calibration into the system at the time of installation.

#### **Grid Selection**

Selects grid operation which can be preset at the time of calibration to compensate for the effects of the grid (typically useful from 80kVp to 125kVp).

#### **Density Control**

Selection of Optical Densities lighter or darker than the normal setting.

#### **Exposure Termination Indicators**

AEC LED (green) - Termination by Mobil-AID Automatic Exposure Control.  
GEN LED (red) - Termination by generator timer set for backup.  
mAs LED (red) - Termination after 3.2 seconds, factory set as a second safety backup.

#### **Reset**

If an exposure has been terminated by the backup generator setting ("GEN"), or if the maximum allowable exposure time (3.2 seconds) has been sensed ("mAs"), the Reset control must be manually operated to allow additional exposures. **The need to activate the RESET control should be interpreted by the operator as a potential radiation safety warning.**

### 3.0 SPECIFICATIONS

#### 3.4 Interface Requirements

The interface is made at the x-ray generator microprocessor board AEC Logic (J213) and AEC Power (J214) connectors. The signals required for operation are listed below. Refer to Section 4.0 for installation instructions.

##### **Analog kV**

An analog signal generated by the x-ray generator (J213 pin 12) which is proportional to kV (10VDC = 125kV) is used to select points along a kV compensation curve to match the AEC to the actual screen-film response.

##### **Exposure Start (X-Ray ON)**

An analog signal generated by the x-ray generator (J213 pin 12) for the duration of the exposure. This is the same signal that is used for analog kV. This signal is modified on the 61049D Interface board inside the Mobil-AID AEC Model D1323.

##### **Exposure Termination (AEC Stop)**

A 5VDC signal is provided to the x-ray generator (J213 pin 24) by the AEC to terminate the exposure.

##### **AEC ON**

A 12VDC signal provided to the x-ray generator (J213 pin 1) by the AEC to indicate to the x-ray generator whether the AEC is on or not.

##### **Power**

Power is provided by the Picker Meteor:

Voltage	Interface Connection	Maximum current
+5VDC	J214 pin 1	0.5A
+15VDC	J213 pin 17	0.5A
-15VDC	J213 pin 21	0.5A

#### 3.5 Physical Parameters

##### **Temperature and Humidity**

Storage	-55 degrees C to 85 degrees C, 95% RH
Operating	0 degrees C to 50 degrees C, 90% RH, non-condensing

##### **Dimensions, Weight (Nominal)**

	Size H x W x L cm (inches)	Weightkg (lbs.)
Electronics	12.7 x 12.7 x 18.0 (5.0 x 5.0 x 7.1)	1.1 (2.5)
Paddle	1.3 x 13.5 x 54.5 (0.5 x 5.3 x 21.5)	1.0 (2.2)
Paddle Cable	Retracted: 0.9m (3 feet) Extended: 4.6m (15 feet)	0.3 (0.7)

### 3.0 SPECIFICATIONS

#### 3.6 Regulatory Compliance

##### **Underwriters Laboratory, Inc.:**

Complies with all current requirements of UL 187 X-ray Apparatus when labeled:

X-ray equipment classified by Underwriters Laboratories, Inc. with respect to electrical fire, shock, and mechanical hazards only. 770R.

##### **Center for Devices and Radiological Health:**

This product complies with radiation performance standards under the Federal Food, Drug and Cosmetic Act, when labeled:

Complies with F.D.A. Radiation Performance Standards 21 CFR, Subchapter J.

## 4.0 INSTALLATION INSTRUCTIONS

### 4.0 INSTALLATION INSTRUCTIONS

Note to FDA (US & Canada only):

The Mobil-AID Automatic Exposure Control is a CDRH certified component. When installation and calibration are complete, you must fill out an FDA Assembler's Report.

The Picker Meteor is a battery powered x-ray generator. Disconnecting the line cord (for the battery charger) does not remove the internal voltages, which are potentially dangerous and have high current capabilities. **During the installation the Picker Meteor key switch must be in the OFF position. Precautions must be used and under no circumstances should the terminals of the key switch be contacted.**

Note: The Picker Meteor mobile x-ray generator may require an upgrade of firmware for AEC operation. Make certain that the generator is equipped with AEC firmware release 3.00 and upwards. may require an upgrade of firmware for AEC operation. Make certain that the generator is equipped with AEC firmware release 3.00 and upwards.

### 4.1 Equipment Supplied

The Model D1323 Mobil-AID AEC includes all the assemblies, cables and hardware required for a complete interface with the Picker Meteor x-ray generator. The following table lists the individual components by their replacement part numbers.

Description	AID Part No.
D1323 mounting bracket	51316
D1323 owner's manual	69266A
Kit, D1323 installation hardware(includes drill bit and template)	70588
AEC electronics package(includes duplicate rating label, p/n 529101)	70590
Paddle holder assembly	70591
AEC control / display assembly	70593
Cable, control / display	75024
Cable, paddle (internal)	75025
Cable, logic	75031
Cable, paddle (external)	75032
Cable, 2-conductor power supply	75033
Paddle/dual field ion chamber	77044

### 4.2 Equipment Required

- Assorted screwdrivers (standard and Phillips head).
- Assorted box wrenches or nut drivers, inch sized.
- High speed drill

## 4.0 INSTALLATION INSTRUCTIONS



### 4.3 Installation Procedure (refer to Figures 4.1 through 4.7)

#### 4.3.1 Electronics Assembly Installation

1. Refer to Figure 4.1. Open the x-ray generator top panel (refer to Section 4.4.1 and Figure 4.4 for top panel removal). Use the 2 existing 5/16-18 x 5/8 screws and 5/16 lock washers to mount the electronics mounting assembly in place. Note: It may be necessary to loosen the bolts securing the x-ray generator power inverter card cage, shift the card cage toward the operator-side and resecure the bolts in order to make room for the Mobil-AID AEC electronics assembly (see Figure 4.5).
2. Connect the 26-conductor flat wire generator interface cable (AID p/n 75031) from the Mobil-AID AEC mother board, 61037A, P9 connector header to the microprocessor board J213connector (see Figure 4.6). Connect the 2-conductor power supply cable (AID p/n 75033) from the Mobil-AID AEC mother board, 61037A, P8 connector header to the microprocessor board J214 connector. Be sure to dress the cables using existing cable runs to avoid sharp edges and moving parts.
3. Affix the duplicate rating label (AID p/n 529101) to the outside of the x-ray generator cabinet in a visible location near the existing generator rating labels. This label duplicates the information included on the Mobil-AID AEC electronics package and is required by the U.S. F.D.A.

**Note:** If the duplicate rating label is damaged or removed or if the generator cabinet is replaced, contact the manufacturer with the model number and serial number of the AEC unit (obtained from the rating label on the AEC electronics package) for a replacement label.

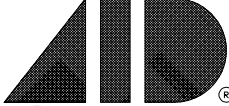
#### Duplicate Rating Label

	ADVANCED INSTRUMENT DEVELOPMENT, INC. 1011 N. 25TH AVE. MELROSE PARK, IL 60160 U.S.A.	P/N 529101
MODEL: _____		
MANUFACTURED: _____		
SER. NO.: _____		
VOLTAGE: _____ AMP: _____		
PRODUCT COMPLIES WITH H.H.S./F.D.A. PERFORMANCE STANDARD 21 CFR SUBCHAPTER J. DUPLICATES IDENTIFICATION WITHIN THIS ENCLOSURE, REQUIRED BY U.S. F.D.A.		

## 4.0 INSTALLATION INSTRUCTIONS

### 4.3.2 Paddle Holder Installation

1. Position the aluminum paddle holder template against the right hand side panel of the x-ray generator as shown in Figure 4.2.
2. Mark the locations of the three holes with a center punch. Remove the template and remove the right hand side panel from the x-ray generator (refer to Section 4.4.2 and Figure 4.7 for side panel removal). Take care of short internal handswitch cable! Disconnect the x-ray pendant switch cable from microprocessor board (remove P205). Drill the 3 holes with the supplied 0.203" drill bit. Be certain to remove all metal chips and burrs.
3. Insert the paddle holder assembly mounting studs through the holes and securely fasten the assembly in place using the 10-32 keps nuts supplied.
4. Refer to Figure 4.3. Loosen the cable clamp at the point where the high tension cables enter the x-ray generator. Route the long straight tail of the external paddle cable (AID p/n 75032) through the cable clamp and secure the cable clamp. Connect the external paddle cable to the internal paddle cable (AID p/n 75025) on the electronics assembly mounting bracket and secure using the attached hardware.
5. Reinstall the right hand side panel.
6. Place the Mobil-AID AEC paddle in the paddle holder.

### 4.3.3 Control/Display Assembly Installation

1. Position the 34-conductor flat wire control / display cable (AID p/n 75024) between the x-ray generator top panel and the x-ray tube column as you close the top panel.

Note: The x-ray generator top panel must be in its fully locked position before performing Step 2.

2. Remove the adhesive backing from the Velcro<sup>®</sup> strip on the back of the control / display assembly. Align the control / display assembly with the center of the x-ray tube column. Be certain that the control / display assembly is touching the x-ray generator top panel as you slide the control / display assembly into place affixing the adhesive of the Velcro firmly in place on the x-ray tube column as shown in Figure 4.3.
3. Open the x-ray generator top panel (refer to Section 4.4.1 and Figure 4.4). Remove the control / display assembly, if necessary, by unhooking the Velcro strip which holds it in place. Connect the 34-conductor flat wire control / display cable to the Mobil-AID AEC mother board, 61037A, P1 connector header.

---

<sup>2</sup>Velcro is a registered trademark of Velcro Industries.

## 4.0 INSTALLATION INSTRUCTIONS

Figure 4.1

View From Above X-ray Generator with Top Panel Removed

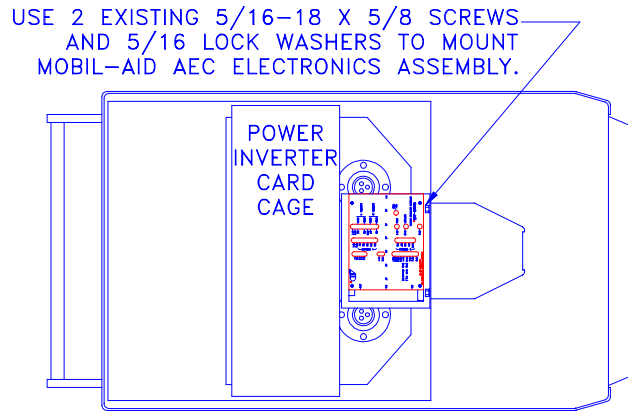
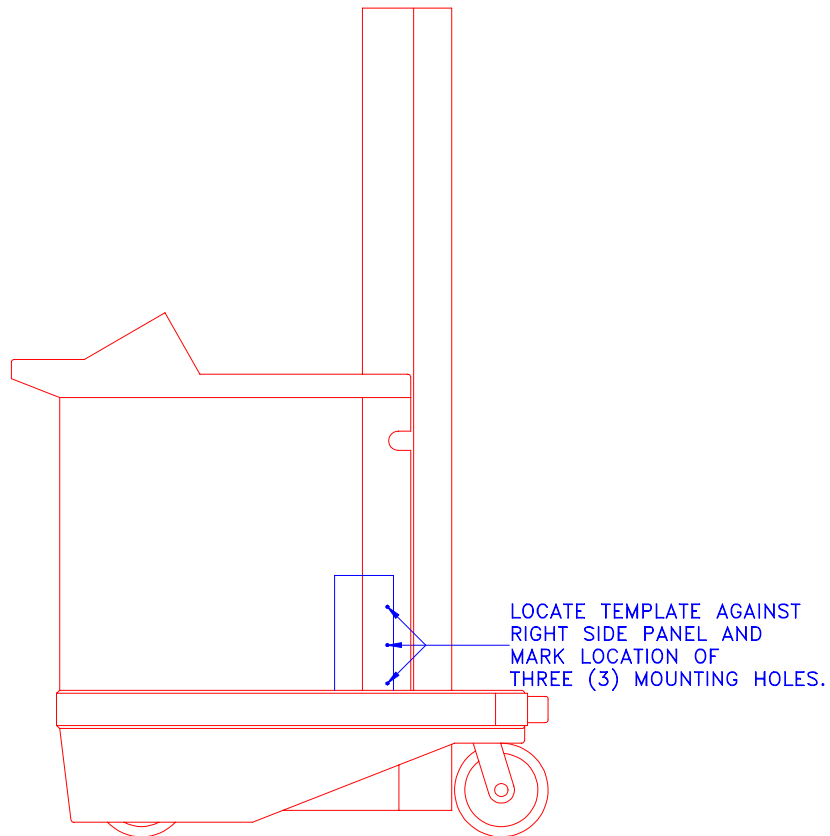

Figure 4.2

Paddle Holder Template



## 4.0 INSTALLATION INSTRUCTIONS

Figure 4.3

### External Mounting

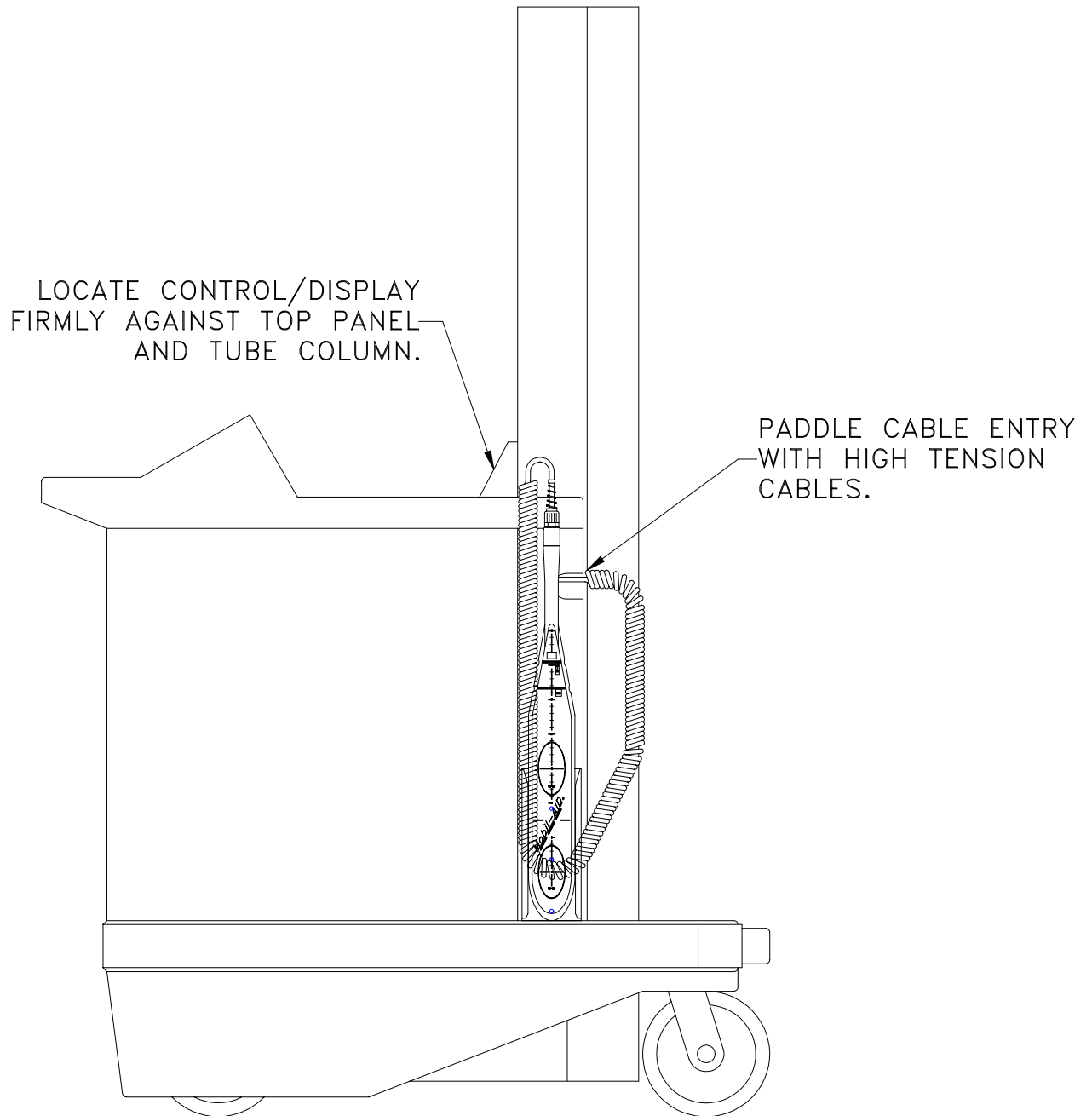

## 4.0 INSTALLATION INSTRUCTIONS

### 4.4. Cover Removal & Disconnecting DC Power

When replacing covers after a service operation, follow the reverse sequence i.e. top cover is removed first and replaced last. Always disconnect DC Power before attempting any service.

Note: If calibration is to follow immediately, leave top cover off until calibration is complete.

#### 4.4.1 Lifting and Removing Top Cover - (Refer to Figure 4.4)

##### Lifting Top Cover

1. Unplug the AC Line Cord from the wall outlet.
2. Extend the x-ray tube head as high as it will go (to the top of the mast).
3. Turn the system keyswitch OFF.
4. Disconnect the x-ray pendant switch from the receptacle below the drive handle.
5. Remove the drive handle shields on right and left underside of the drive handle assembly. Two 3/32" internal hex head (8 x 32) screws secure each shield to the unit.
6. Loosen the top cover securing hardware under each handle assembly (7/16" external hex head).
7. Lift the top cover from the operator's side approximately 10cm (4 inches).
8. Pull the top cover towards the operator handle side.
9. Slowly lift the top cover off the unit.
10. Rest the top cover against mast structure as shown in Figure 4.4.
11. Support the operator's side of the top cover with the prop rod.

##### Removing Top Cover

12. Disconnect the control panel ribbon cable from the microprocessor board.
13. Disconnect the park switch and keyswitch connectors.
14. Disconnect the top cover grounding wire.
15. Carefully place cover in a secured area.

## 4.0 INSTALLATION INSTRUCTIONS

Figure 4.4

### Lifting and Removing Top Cover

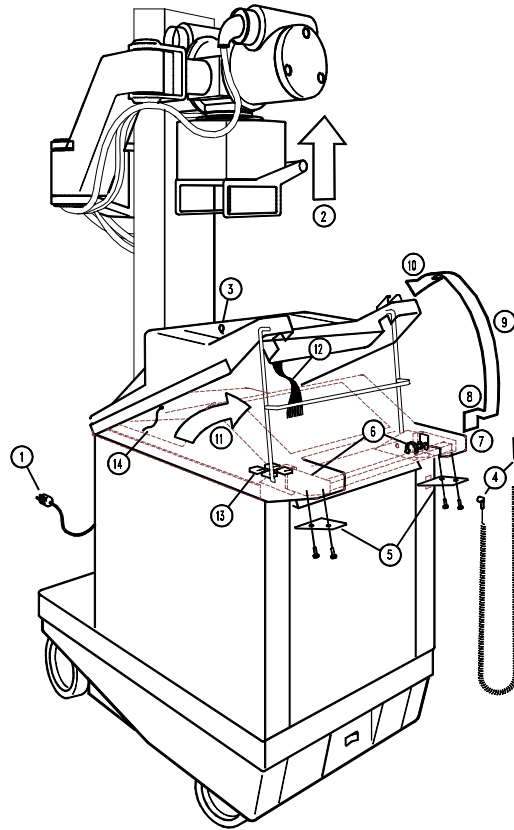
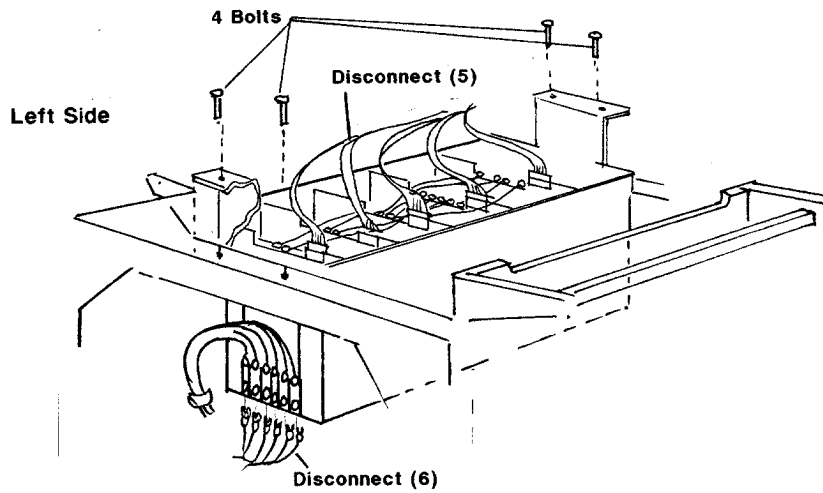

Figure 4.5

### Relocating Card Cage



## 4.0 INSTALLATION INSTRUCTIONS

Figure 4.6

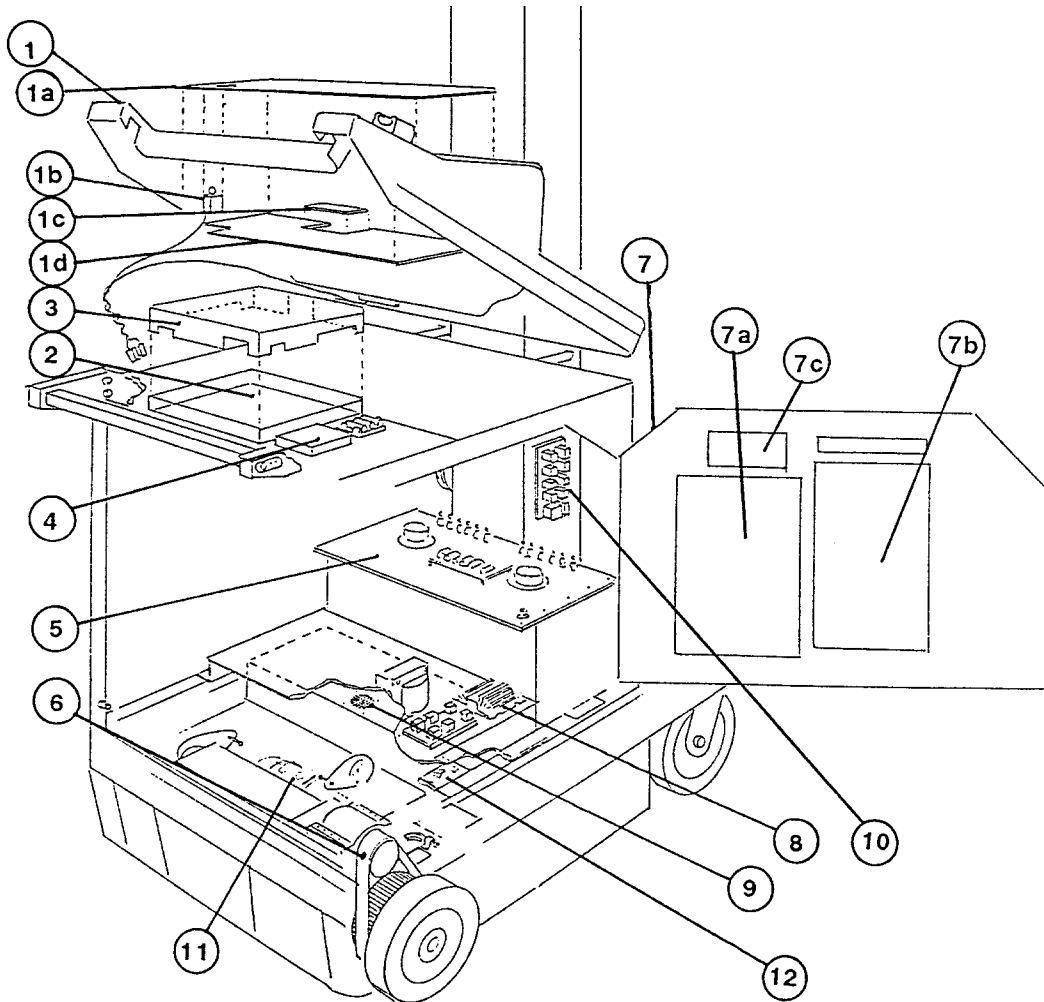

### Component Identification

- |     |                                      |     |                                |
|-----|--------------------------------------|-----|--------------------------------|
| 1.  | Top Cover                            | 7.  | Right Side Panel               |
| 1a. | Control Panel                        | 7a. | D.C. Motor Drive Control Board |
| 1b. | Keyswitch                            | 7b. | Rotor Board                    |
| 1c. | LCD Display                          | 7c. | Phase Shift Capacitor          |
| 1d. | Display Board                        | 8.  | Battery Charger                |
| 2.  | Microprocessor Board                 | 9.  | Cooling Fan                    |
| 3.  | Microprocessor Shield                | 10. | Arm Interconnect Bd.           |
| 4.  | Low Voltage Power Supply             | 11. | Motor Interconnect Bd.         |
| 5.  | H. V. Tank with L. V. Feedback Board | 12. | Fan Interconnect Bd.           |
| 6.  | Right Drive Wheel and Gear Belt      | 13. | Discant                        |

## 4.0 INSTALLATION INSTRUCTIONS

### 4.4.2 Removing Upper Right Cover - (Refer to Figure 4.7)

#### **! CAUTION !**

The Upper Left and Upper Right Covers hold the Cassette Drawer in the unit. When removing the covers proceed carefully to prevent the Cassette Drawer from falling to the floor.

1. Lift the top cover as per paragraph 4.4.1 of this section.
2. Remove the microprocessor board shield (secured by four phillips screws).
3. Disconnect the x-ray pendant switch cable from microprocessor board (remove P205).
4. Release the two (phillips) 1/4 turn fasteners at each top end of the upper right cover. Access the fasteners through the hole in the cassette holder and the hole on the inside right wall of the unit.
5. Remove the upper right cover screw near the mast structure.
6. Remove the electrical ground wire from between the upper right cover and the unit's frame.
7. Remove the upper right cover by lifting the cover off of the locating pins. While removing the cover, back feed x-ray pendant switch cable through the chassis (the cable is attached to the connector on the cover).
8. Remove the right panel screws (qty 3).

Note: When replacing the cover, slide the grommet and the tube head cables back into the upper right cover cut-out. Position the cover around the operator's side first, then over the locating pins near the base of the mast, and the two locating pins below the left panel.

## 4.0 INSTALLATION INSTRUCTIONS

Figure 4.7

### Removing Covers

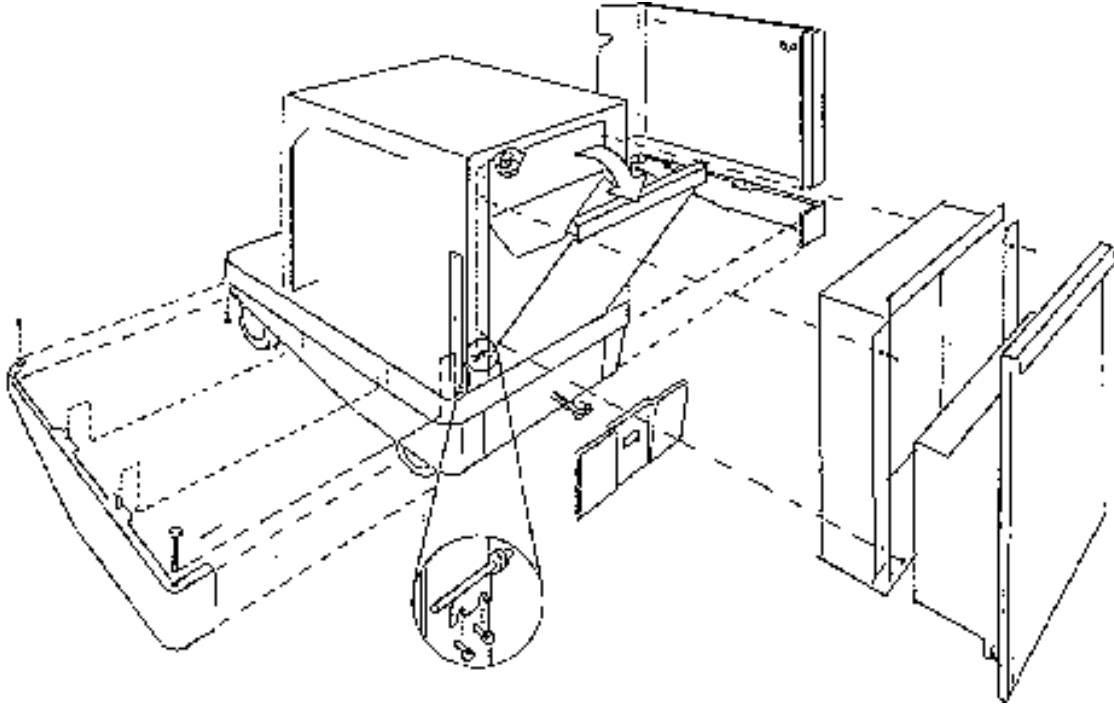

## 5.0 CALIBRATION INSTRUCTIONS

### 5.0 CALIBRATION INSTRUCTIONS

The purpose of the calibration procedure in this chapter is to match the Mobil-AID AEC to the user's particular generator and to the x-ray absorption characteristics of the specific screen-film and grid combinations to be used with that generator.

**The Calibration/Test Set Up (Section 5.1) shows the proper positioning of the x-ray tube arm, Mobil-AID paddle, film cassette and phantom.**

**The Paddle Gain Adjustment and Grid Gain Adjustment (Sections 5.2 and 5.4) match the Mobil-AID AEC to the screen-film and grid combinations.**

**The kVp Compensation Adjustments (Section 5.3) completes the matching of the Mobil-AID AEC to the screen- film combinations by fine tuning five additional calibration set points on the kVp compensation curve. The fine tuning is accomplished by making an X-ray exposure, measuring the resultant Optical Density of the film, adjusting (if necessary) each calibration set point according to a simple formula, and then rechecking with another exposure.**

#### **Equipment Required**

##### X-ray Apparatus

- **Picker Meteor x-ray generator, known to be in good working order and having a properly charged battery set.**
- **X-ray film processor.**
- **X-ray densitometer capable of measuring film Optical Density from 0.5 to 2.5 with accuracy of  $\pm 0.05$  OD.**
- **Fully installed Mobil-AID AEC including a push button assembly, electronics assembly, and paddle/ion chamber.**
- **Film, cassettes and grids (if applicable) - use the same combinations for calibration that will be used for work with patients. Designate one combination as Screen 1 and another as Screen 2. If only one combination is to be used, then make the same calibration adjustments for both screen positions 1 and 2, or move jumper W4 on board 61036B to the storage position to disable screen switching.**

## 5.0 CALIBRATION INSTRUCTIONS

### Tools

- Standard field service tool kit, inch sized.
- **Digital voltmeter, 3-1/2 digits, 20 VDC range, 10 Mohm input impedance, preferably a type allowing battery operation, and probes equipped with clips and probe points. (All voltages measured are referenced to circuit common unless noted otherwise.)**
- **Small Screwdriver for potentiometer adjustments.**

### Other Required Material (see Figure 5.1 for details)

- **Lead apron**
- **Phantom - a clean, flat-bottomed, non-metallic bucket capable of holding at least 25cm (10 inches) of water and at least 13cm (5 inches) wide at the base. Plexiglas<sup>3</sup> is an acceptable alternative to the water phantom.**
- **Blocks - about 2.5cm (1 inch) thick to support the phantom above the paddle and film cassette.**
- **Tape - to secure the paddle and blocks to the calibration work surface.**
- **Lead Sheet - for reproducible back-scatter in test set up. Use a lead apron if a lead sheet is unavailable. Do not use lead apron as a phantom**

### PC Board Access (see Figure 5.2)

Open the x-ray generator top panel (refer to Section 4.4.1 and Figure 4.4). Remove the control / display assembly, if necessary, by unhooking the Velcro strip which holds it in place on the x-ray generator top panel. There is no need to remove the cover of the Mobil-AID AEC electronics assembly. All of the necessary test points and adjustment potentiometers are accessible through the slots and are marked on the cover.

---

<sup>3</sup>Plexiglas is a registered trademark of Rohm and Haas.

## 5.0 CALIBRATION INSTRUCTIONS

### 5.1 Calibration/Test Set Up (See Figure 5.1)

1. Provide a clean, flat, work area for placement of the lead sheet (or lead apron), paddle and a film cassette.
2. Tape the paddle and blocks in position to prevent them from moving during calibration.
3. Position the x-ray tube head for 100cm (40 inch) SID.
4. In considering the location of the x-ray tube arm, provide a safe distance between the x-ray tube and any personnel for safety from radiation scatter.
5. Turn on the Picker Meteor. Use the field light and adjust the collimator to center the x-ray field on Field One of the paddle. Collimate the field to an area of 13cm by 13cm (5 inches by 5 inches) at the paddle so that Field One is entirely in the x-ray beam.
6. Use blocks to support the phantom just above the paddle and film cassette without tipping.
7. Center the phantom in the x-ray field.

#### **Cassettes**

It is important that one specific x-ray cassette be used throughout the entire calibration procedure for a particular screen-film combination. Minor differences from cassette to cassette can cause readings that appear to be erratic and unnecessarily complicate the procedure. The same is true of grids.

#### **CAUTION**

**CERTAIN TESTS REQUIRE THE PRODUCTION OF X-RAYS. FIELD PERSONNEL SHOULD TAKE PRECAUTIONS TO ENSURE THEIR PERSONAL SAFETY AND THE SAFETY OF OTHERS NEARBY. MINIMUM PRECAUTIONS FOLLOW:**

- Wear a lead apron.
- Maintain a safe distance between the x-ray tube and any personnel.
- Minimize radiation scatter through doorways, walls, and floor.

## 5.0 CALIBRATION INSTRUCTIONS

Figure 5.1  
Calibration Test Set Up

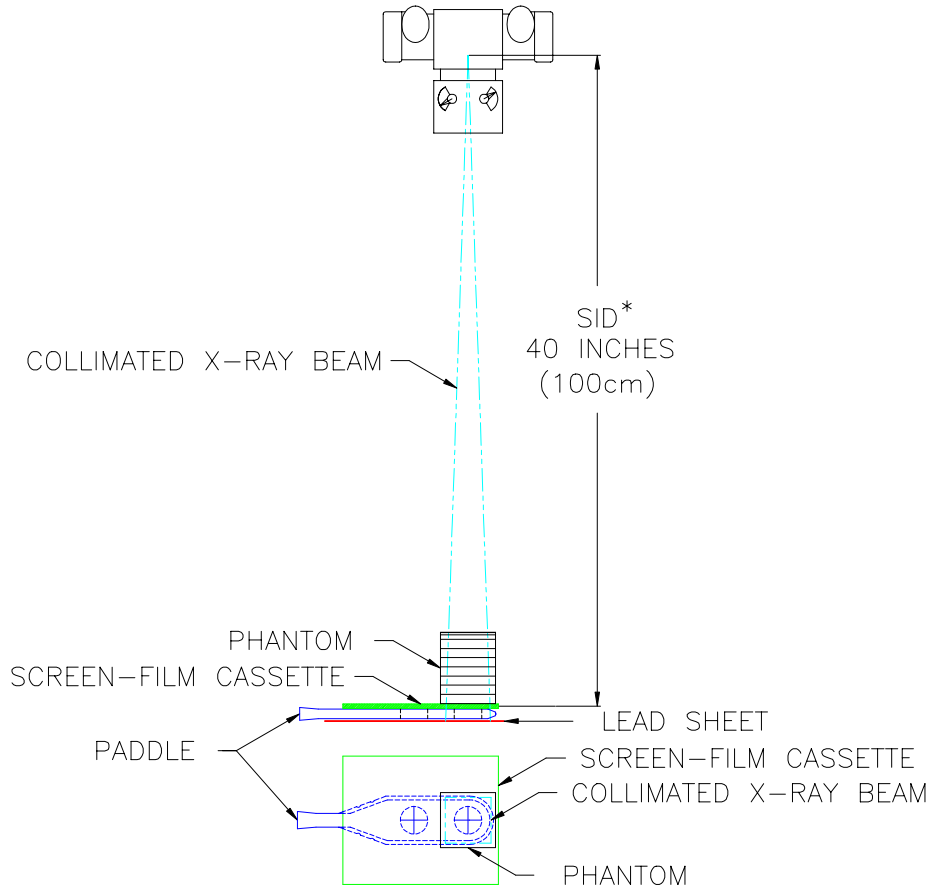

\* WHEN CALIBRATING WITH A GRID, MATCH THE SID TO THE GRID FOCAL DISTANCE.

Phantom - See Section 5.2.5 and Table 5.1 for phantom thickness.

## 5.0 CALIBRATION INSTRUCTIONS

Figure 5.2

Calibration Test Points and Adjustments

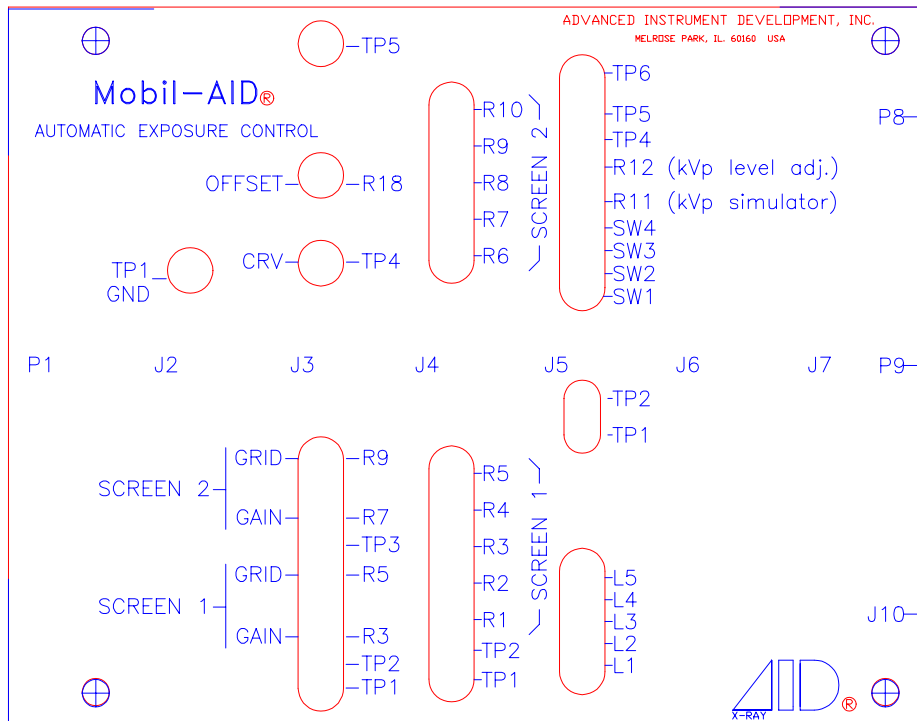
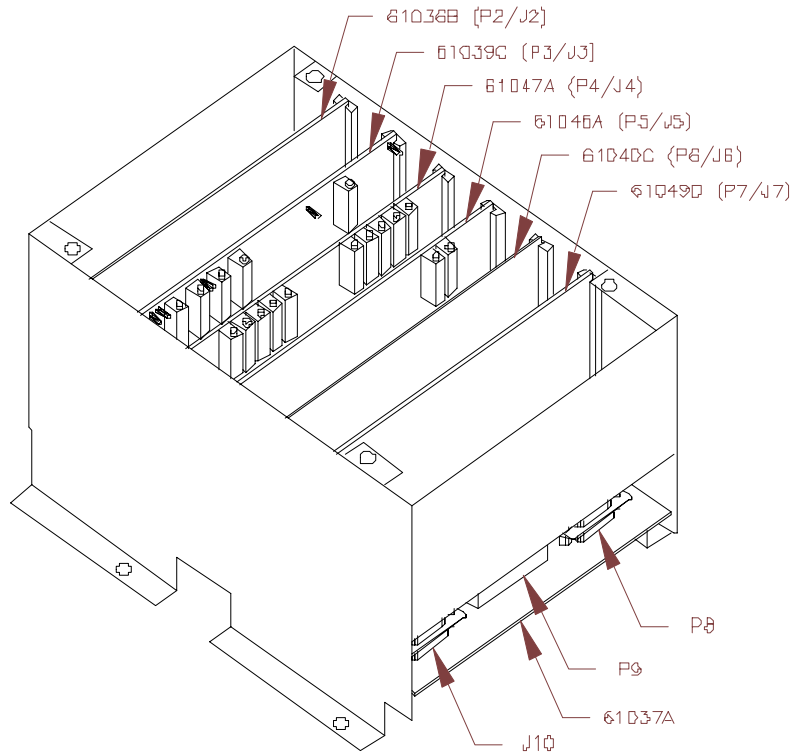

## 5.0 CALIBRATION INSTRUCTIONS

### 5.2 Paddle Gain Adjustment

In this procedure, x-ray exposures with the appropriate placement of the AEC Paddle will be required (see Section 5.1) Keep the beam centered on Field One and the phantom centered in the beam. While calibrating for 1.20 Optical Density, phantom thickness should be adjusted to maintain mAs readings above 4.0mAs.

1. Turn on the AEC and set the amplifier offset for  $0.00V \pm 0.01V$  at 61039C TP3 by adjusting 61039C R18.
2. Select Screen 1, Field One, No Grid and Density normal.
3. Set the Picker Meteor for 110kVp and 100mAs.
4. For 110kVp use a 25cm (10 inch) phantom. See Figure 5.1.
5. Make an x-ray exposure at 110kVp with a loaded film cassette. Check to see that the green "AEC" LED comes on briefly immediately after the exposure. Record the mAs reading.
6. Develop the film and measure and record the average Optical Density (OD) near the center of the exposure.
7. If the Optical Density is  $1.20 \pm 0.05$ , proceed to Section 5.3. If the Optical Density is not  $1.20 \pm 0.05$ , continue with this section.
8. Determine an approximate value of mAs to correspond to  $OD = 1.20$  by using the following equation:

$$\text{New mAs} = [1.20 \div OD (\text{from Step 6})] \times \text{Old mAs (from Step 5)}$$

9. Adjust 61039C R3 (Gain Screen 1) to produce the mAs reading calculated in Step 8. Repeat steps 5. through 7. This equation is an approximation and these steps may need to be repeated to finally obtain the desired OD. The gain potentiometers on 61039C are 15-turn pots. A clockwise adjustment to these pots increases the gain (decreases the mAs).

NOTE: If there is not enough range on the gain adjustment, it may be necessary to lower the Compensation Reference Voltage (CRV) at 110kVp. First turn the gain potentiometer a few turns back off of its endpoint. Turn ON 61046A SW2 and SW3. Adjust 61046A R11 until the voltage at 61046A TP6 is greater than 8.8VDC (kVp level indicator 61046A L5 should be lit). Measure the CRV at 61039C TP4 referenced to 61036B TP1 (0VDC). Adjust 61047A R5 (Screen 1) or 61047A R10 (Screen 2), as needed, substituting the following equation for the equation in step 8 above.

$$\text{New CRV} = [1.20 \div OD] \times \text{Old CRV}$$

Turn OFF 61046A SW2 and SW3 when making exposures and when this procedure is complete.



## 5.0 CALIBRATION INSTRUCTIONS

### 5.3 kVp Compensation Adjustments

This procedure requires the prior calibration of Paddle Gain as given in Section 5.2. X-ray exposures will be required.

Turn the Picker Meteor and Mobil-AID AEC **ON**. **Set the Picker Meteor to 100mAs.**

Position the AEC Paddle as in Section 5.1. Without moving the paddle, place the Screen 1 film cassette and then the phantom in line with the collimator light. Ensure that the SID is 100cm (40 inches).

1. Set the Mobil-AID AEC for Screen 1, Field One, No Grid and Density Control at normal.
2. Select a calibration set point kVp setting on the Picker Meteor and phantom thickness according to Table 5.1. Adjust the phantom thickness to maintain mAs readings above 4.0mAs.
3. Begin at 95kVp and work down through the lower kVp settings (the 110kVp setting was made in Section 5.2).
4. Measure the Compensation Reference Voltage (CRV).
  - a. **Switch ON 61046A SW3.**
  - b. **Adjust 61046A R11 to just turn off the next lower LED and just turn on the LED for the kVp setting listed in Table 5.1.**
  - c. **Measure and record the CRV at 61039C TP4.**
  - d. **Switch OFF 61046A SW3.**

Table 5.1

Calibration Set Point Picker Meteor kVp Setting	kVp Level Indicator 61046A LED	Phantom Thickness cm (inches)	61047A CRV Adjustment Potentiometer		61039C TP4 Final CRV Settings	
			Screen1	Screen2	Screen1	Screen2
110	L5*	25 (10)	R5	R10		
95	L5	23 (9)	R4	R9		
80	L4	20 (8)	R3	R8		
65	L3	15 (6)	R2	R7		
50	L2	13 (5)	R1	R6		

\*To measure the CRV for 110kVp, 61046A R11 must be set for  $\geq 8.8$ VDC at 61046A TP6 and 61046A SW2 must be switched ON. Switch OFF 61046A SW2 after making the measurement.

## 5.0 CALIBRATION INSTRUCTIONS



5. Make an x-ray exposure at the selected kVp with a loaded film cassette.
6. Develop the film and measure the average Optical Density near the center of the exposure. If the Optical Density is  $1.20 \pm 0.05$ , record the CRV<sup>4</sup> in Table 5.1 for future reference and proceed to Step 9.
7. For any point where the Optical Density is not within these limits, calculate by means of the following equation a **new CRV setting to obtain the approximate desired Optical Density**.

$$\text{New CRV} = [1.20 \div \text{OD (from Step 6)}] \times \text{Old CRV (from Step 4)}$$

8. Adjust the CRV for the selected kVp using the potentiometer on PCB 61047A as indicated in Table 5.1 to give the new CRV calculated in Step 7. Repeat Steps 4, 5 and 6.
9. Repeat Step 2 through Step 6 for all the kVp settings listed in Table 5.1.

### 5.4 Grid Gain Adjustment (optional)

When a grid is to be used with the cassette, a separate gain adjustment is needed. Select **Grid "Yes" operation**. **Place the grid in front of the same cassette that was used in Section 5.2. If necessary, adjust the SID to match the focal distance of the grid. Repeat Section 5.2 Step 5 through Step 10, adjusting 61039C R5 instead of 61039C R3 in Step 5.2 10.**

If cassettes with built-in grids are to be used, be certain that they use the same screen-film combination that was used in Section 5.2.

If grids are not to be used at the installation, adjust 61039C R5 to produce the same mAs readings as 61039C R3 in Section 5.2 Step 10 using the same screen-film combination and filtration, or move jumper 61036B W5 to b/c (storage position) to disable switching to Grid "Yes" selection.

---

<sup>4</sup>Note: CRV settings should not be allowed to exceed 3.20VDC at any kVp setting. If it is determined that a CRV above 3.20VDC is required, then the CRV for that kVp should be set to 3.20VDC and the Paddle Gain Adjustment (Section 5.2) should be repeated using that kVp setting and the kVp Compensation Adjustments (Section 5.3) should be repeated at the four (4) remaining kVp settings.

## 5.0 CALIBRATION INSTRUCTIONS

### 5.5 Screen 2

In Section 5.2 adjust 61047 R10 instead of 61047 R5 (5.2 Step 4) and 61039C R7 instead of 61039C R3 (5.2 Step 10.)

In Section 5.3 adjust 61047 R6, R7, R8, R9 and R10 instead of 61047 R1, R2, R3, R4 and R5 respectively.

In Section 5.4 adjust 61039C R9 instead of 61039C R5.

If a second screen-film combination is not utilized, set the Screen 2 paddle gain 61039C R7 and the Screen 2 grid gain 61039C R9 to produce the same mAs readings obtained for Screen 1. Then match the CRV settings for Screen 2 (61047 R6, R7, R8, R9, and R10) with those obtained for Screen 1 in Section 5.3. Note: Screen 2 must be selected and the prep switch must be prepped in order to register the CRV at 61039C TP4 for each kVp setting.

Alternatively, if a second screen-film combination is not used, move jumper 61036B W4 to b/c (storage position) to disable screen switching.

### 5.6 Both Fields

The output of Fields One and Two are matched at the factory. There is no field calibration adjustment of these settings. However, before releasing the unit for use, it is suggested that the operation of Both Fields be checked.



Select Both Fields on the Mobil-AID AEC push button assembly. Center the x-ray beam on Field One. Place a lead sheet over Field Two. Place a film cassette and 20cm (8 inch) phantom in the beam. Set the Picker Meteor for 80 kVp and 100mAs. Make an x-ray exposure and record the mAs reading.



Center the x-ray beam on Field Two. Place a lead sheet over Field One. Place a film cassette and 20cm (8 inch) phantom in the beam. Set the Picker Meteor for 80 kVp and 100mAs. Make an x-ray exposure and record the mAs reading.

The mAs reading obtained for Field Two should be within 5% of the reading obtained for Field One.

## 5.0 CALIBRATION INSTRUCTIONS

### 5.7 Conclusion of Calibration

It is strongly suggested that a diagnostic quality anatomical or radiological phantom be used to provide an initial baseline quality check of the system.

It is recommended that the Mobil-AID AEC "Normal" calibration be left at 1.20 OD so that radiographs using the various mobile/portable x-ray generators equipped with Mobil-AID AEC are all directly comparable within a department and even from one hospital to another. The Density Control switches are provided for users who may desire an Optical Density other than the normal 1.20 OD.

Though not a recommended procedure, if the users prefer that their "Normal" be other than the 1.20 Optical Density provided by the calibration procedure, the input amplifier gains on PCB 61039C (R3 and R7 for no grid and R5 and R9 for grid) can be adjusted accordingly. It is not necessary to reset the CRVs.

The Mobil-AID Automatic Exposure Control system is now adjusted and calibrated.

Be sure to complete an FDA Assembler's Report (US & Canada only) or other required documentation for this installation.

## 6.0 PRINCIPLES OF OPERATION

### 6.0 PRINCIPLES OF OPERATION

The following sections are intended to provide service personnel with a basic understanding of the key elements of the Mobil-AID AEC system.

#### 6.1 Basic System Blocks (Refer to Figures 6.1 and 6.2)

- X-ray source
- Patient anatomy
- Screen-film cassette
- Paddle - Contains two nominal 7.6cm (3 inch) diameter ion chambers. X-ray flux is converted to a small proportional ion current which is amplified and time integrated.
- The integrator is held in a reset condition. At the start of an exposure the reset is removed. The integrated paddle signal is preamplified and transmitted to the input amplifier.
- Gain Switching Circuitry - Remotely activated at the push button assembly to select the use of Screen 1 or Screen 2 gain, corresponding to screen-film combination 1 or 2. Selection of gain adjustments for Grid "Yes" and Grid "No" operation are also accommodated. The amplified paddle signal is then routed to the comparator circuits.
- Screen-film absorption matching - Five kVp calibration set point potentiometers are adjusted to establish a kVp dependent response curve which matches that of the screen-film combination being used.
- An analog kV signal is supplied by the Picker Meteor which represents the selected kV. The kV signal is processed to select a Compensation Voltage (CV) from the response curve.
- The density control can be used to raise or lower the CV by up to 50% to provide a Compensation Reference Voltage (CRV) to the comparator circuit.
- The anticipate circuit modifies the CRV at the start of an exposure to terminate short x-ray exposures prior to normal extinction to compensate for inherent turnoff delays (Lead Time) in the generator.
- The Comparator controls and precisely terminates the exposure when the paddle signal is equal to the CRV.

## 6.0 PRINCIPLES OF OPERATION

Figure 6.1

### Basic System Blocks

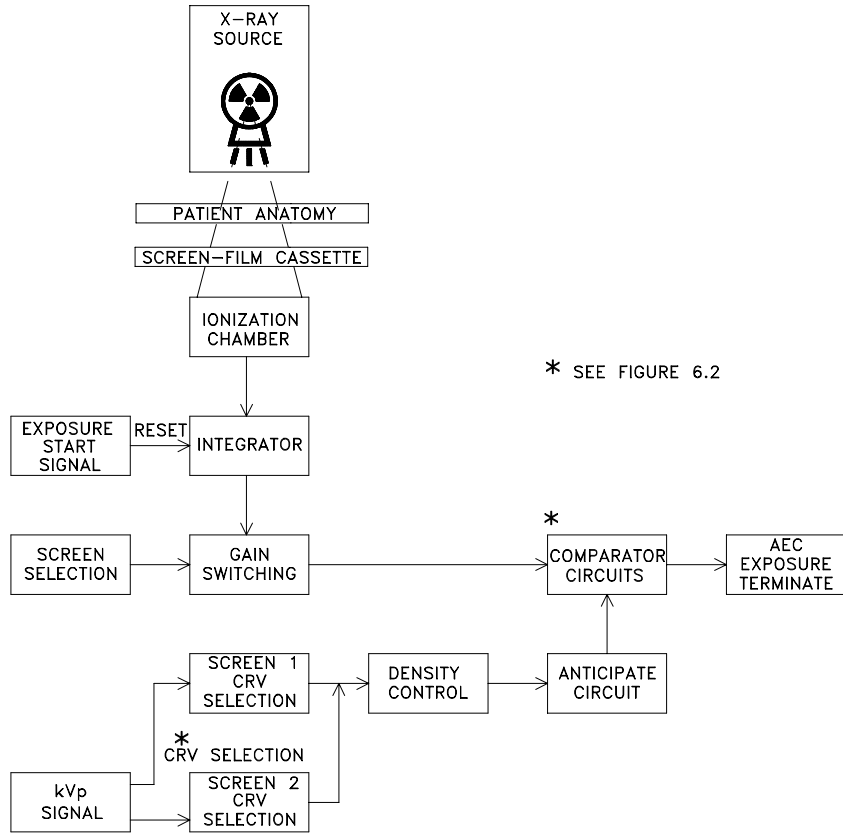
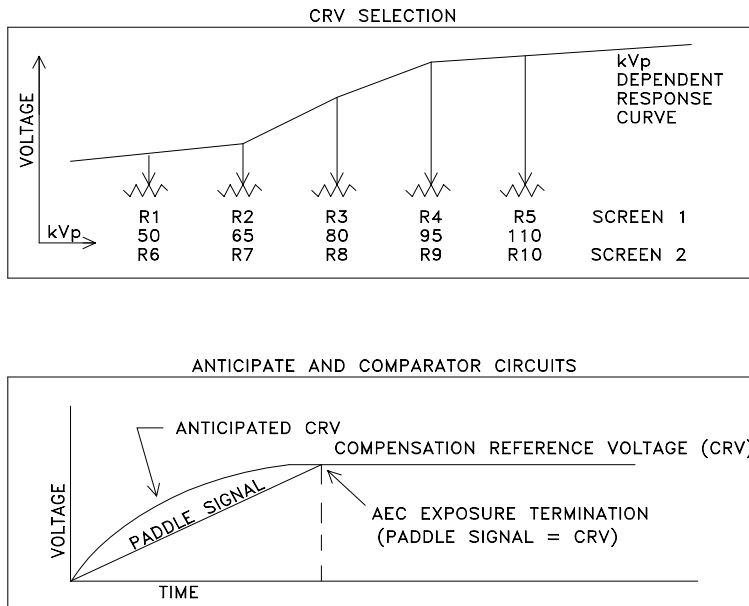

Figure 6.2



## 6.0 PRINCIPLES OF OPERATION

### 6.2 Diagnostic/Troubleshooting Guide

#### Faultfinding - Diagnostics

The following is a list of possible problems and their likely corrections. The list is not comprehensive. Additional questions should be referred to the factory or service center. It is assumed that the Picker Meteor x-ray generator is in proper working order, and this should be confirmed by normal manual operation of the Picker Meteor after simply switching off the Mobil-AID AEC.

#### Preliminary Checks:

Check to see that the Picker Meteor operates properly with the Mobil-AID AEC power turned off.

Check all cabling as described in Section 4.0.

Check to see that all cable connectors are securely fastened and held in place with appropriate hardware. Also check to see that all cables are routed and secured to avoid sharp edges and moving parts.

Check to see that all circuit boards are correctly plugged into their proper connectors.<sup>5</sup>

Check to see that the fuses (61037A F1, F2 and F3) are good.

Check to see that all the selectable jumpers are positioned correctly (see Section 7.3.)

#### **SYMPTOM: Power "ON" LED is off.**

The power to the Mobil-AID AEC may be missing.

- Turn on the Picker Meteor.
- Check the fuses (61037A F1, F2 and F3) and replace those that are open.

Problems may exist on 61036B or 61040D.

#### **SYMPTOM: The Power "ON" LED is blinking and the Picker Meteor mAs display reads " E. "**

This is caused by the paddle interlock exposure inhibit circuit. The paddle or paddle cable is disconnected or the paddle cable is damaged.

- Check the connections or if necessary replace the cable.

Logic problems may exist on 61040D.

---

<sup>5</sup> Whenever removing or replacing any of the Mobil-AID AEC circuit boards, be certain that all power is removed from the unit. Turn off the x-ray generator.

## 6.0 PRINCIPLES OF OPERATION

### **SYMPTOM: "GEN" LED appears after exposure.**

The generator back-up time (related to mAs setting) may be too short.

- Set the backup mAs to about 4x the expected value.

The generator x-ray output may be low.

- Check the generator kVp setting and collimation.
- Operation of the Mobil-AID AEC below 54kVp is not recommended when using certain lead-backed cassettes.

The paddle ion chambers may not be in the collimated x-ray beam.

- Correct the placement of the paddle.

The paddle cables may be damaged or disconnected.

- Check the continuity and repair or replace as needed.

The paddle may be damaged or disconnected.<sup>6</sup>

- Check the paddle output at 61039C TP3 using a storage oscilloscope. Look for a positive ramping signal rising from 0.00VDC. External Trigger via 61049D P7-6 (Exposure Start). Refer to Figure 6.2. Refer to Figure 6.2.

Logic problems may exist on 61039C or 61040D.

Once the problem has been resolved press RESET to clear the "GEN" LED.

---

<sup>6</sup> **Do Not attempt to open the paddle. It is sealed and is not field serviceable. The manufacturer cannot be responsible for units that show evidence of tampering.**

## 6.0 PRINCIPLES OF OPERATION

### **SYMPTOM: "mAs" LED appears after exposure.**

This indicates that the Mobil-AID AEC terminated the exposure at 3.2 seconds. If the Picker Meteor is set at maximum mAs, this can be normal functioning of this redundant safety backup to prevent excessive radiation.

Look for the same problems listed above for "GEN" LED.

The "mAs" LED may also light before an exposure if one of the power supply voltages is missing.

- Check the fuses (61037A F1, F2 and F3) and replace those that are open.
- Check the regulated power supplies (+/-12V and +5V) at 61049D TP1, TP2 and TP3.

Problems may exist on 61036B, 61039C or 61040D.

Once the problem has been resolved press RESET to clear the "mAs" LED.

### **SYMPTOM: Erratic mAs and exposure times.**

Check to see that the film's Optical Density (OD) remains relatively constant from shot to shot in spite of changes in mAs. If not:

- Check the fuses (61037A F1, F2 and F3) and replace those that are open.
- Check the regulated power supplies (+/-12V and +5V) at 61049D TP1, TP2 and TP3.
- Check the connections of the paddle and paddle cables.
- Check the continuity of the external paddle cable in both the extended and relaxed (coiled) conditions.
- Check the paddle output at 61039C TP3 using a storage oscilloscope. Look for a positive ramping signal rising from 0.00VDC. External Trigger via 61049D P7-6 (Exposure Start). Refer to Figure 6.2. Refer to Figure 6.2.

Logic problems may exist on 61036B, 61039C or 61040D.

## 6.0 PRINCIPLES OF OPERATION

### **SYMPTOM: Exposures are uniformly too light or too dark at all kVp settings.**

The Paddle Gain Adjustment and/or Grid Gain Adjustment may be incorrect.

- Repeat the calibration procedures for the Paddle Gain Adjustment (Section 5.2) and Grid Gain Adjustment (Section 5.4).

The density switch setting may be incorrect.

- Adjust density switch setting as needed.

Logic problems may exist on 61039C.

### **SYMPTOM: Exposures are too light or too dark at some kVp settings.**

The kVp compensation may be incorrect.

- Recheck the kVp Compensation Adjustments in Section 5.3.

The kVp selected may be too low for the anatomy being radiographed. Operation of the Mobil-AID AEC below 54kVp is not recommended when using certain lead-backed cassettes.

- Check the paddle output at 61039C TP3 using a storage oscilloscope. Look for a positive ramping signal rising from 0.00VDC. External Trigger via 61049D P7-6 (Exposure Start). Refer to Figure 6.2. Refer to Figure 6.2.
- Use a higher kVp setting.

The kVp selected may be too high for the anatomy being radiographed. Operation of the Mobil-AID AEC is not recommended for exposures less than 0.4mAs.

- Use a lower kVp setting.
- Use a larger SID.
- Use a slower speed screen-film/grid combination.

Logic problems may exist on 61047.

## 7.0 DOCUMENTATION

### 7.0 DOCUMENTATION

#### 7.1 List of Drawings

<b>Schematics</b>	<b>version</b>	<b>Component Location</b>	<b>version</b>	<b>Description</b>
WD1323	18SEP96			AEC block diagram
S0272	25SEP92			Paddle block diagram
S61036B	24AUG93	61036B	3NOV94	On/off, screen, grid and field selection board
S61037A	09SEP94	61037A	01/28/88	Mother board
S61038A	19JAN93	61038A	3NOV94	Control/display board
S61039C	17SEP92	61039C	25OCT94	Input amplifier, anticipate, density and reset board
S61040D	24APR92	61040D	21NOV94	Logic board
S61046A	01JAN93	61046A	25OCT94	Analog kVp computer board
S61047A	28MAY93	61047A	19APR95	CRV adjust board
S61049D	15SEP94	61049D	15NOV96	Interface board

#### 7.2 Replacement Parts List

The following spare parts and assemblies are available for field replacement purposes. Repair of electronic circuit assemblies should be on a replacement basis and defective assemblies sent to the factory or repair depot for ultimate repair.

Description	AID part no.
D1323 owner's manual	69266A
D1323 electronics package replacement kit (includes the following PC board assemblies)	70590 <sup>1,2</sup>
On/off, screen, grid, and field selection board	61036B <sup>1</sup>
Mother board	61037A
Input amplifier, anticipate, density and reset board	61039C <sup>1</sup>
Logic board	61040D <sup>1</sup>
Analog kVp computer board	61046A <sup>1</sup>
Analog CRV selection board	61047A <sup>1</sup>
Interface board	61049D <sup>1</sup>
Extender board	61051A
D1323 paddle holder assembly replacement kit	70591
D1323 AEC control / display panel replacement kit (includes the 61038A PC board assembly)	70593
Cable, D1323 control / display	75024
Cable, D1323 paddle (internal)	75025
Cable, D1323 generator interface logic	75031
Cable, D1323 paddle (external)	75032
Cable, D1323 2-conductor power supply	75033
Paddle/dual field ion chamber	77044 <sup>1</sup>

<sup>1</sup> Replacement of any of these components would require the performance of the calibration procedures described in Section 5.0.

<sup>2</sup> When replacing this component, be certain to replace the existing duplicate rating label, 529101, on the x-ray generator cabinet with the new label accompanying the replacement package as described in Section 4.3.1.

## 7.0 DOCUMENTATION

### 7.3 Programmable Jumpers

For use with the Picker Meteor the Mobil-AID AEC program jumpers should be positioned as follows:

PCB No.	Jumper	Position	Function
61036B	W1	b/c	+12VDC regulator (active)
	W2	a/b	AEC auto power-on (active)
		or b/c	AEC auto power-on (inactive)
	W3	b/c	-12VDC regulator (active)
	W4	a/b	Screen select (active)
or b/c		Screen select (inactive)	
	W5	a/b	Grid select (active)
		or b/c	Grid select (inactive)
	61039C	W1	b/c
	W2	a/b	Anticipate CRV level (fixed)
	W3	b/c	Anticipate timer (fixed)
61040D	W1	b/c	Default-terminate (3.2 seconds)
	W2	a/b	Paddle interlock exposure inhibit (active)
	W3	a/b	mA reference voltage (fixed)
	W4	a/b	Terminate signal (pulse)
61046A	SW1	On	kVp level indicators (on)
	SW2	Off	Multiplier kVp input (active)
	SW3	Off	kVp level simulator (inactive)
	SW4	Off	kVp level sweep (inactive)
	W1	a/b	kVp filtration (inactive)
	W2	a/b	kVp input (DC)
	W3	b/c	kVp reference (ground)
61047A	W1	b/c	Multiplier CRV input (active)

## 7.0 DOCUMENTATION

### 7.4 61037A Mother Board Connector Listings

Note: Signals marked with the "L" symbol are low-active signals.

#### P1 CONTROL/DISPLAY CABLE - 75024

61037A P1 pin out	Signal Name	Low-Active Signal	Source / Destination
1	+5 VDC when AEC is On		From J2-23
2	(not used)		From J6-17
3	Ground		From J9-22
4	(not used)		From J6-11
5	+12 VDC when AEC is On		From J2-22
6	(not used)		From P1-33
7	Ground		From P9-22
8	"++" Density LED	L	From J3-6
9	+5 VDC when AEC is On		From J2-23
10	Density Down Selection	L	From P11-10
11	Density Up Selection	L	From P11-11, P11-12
12	Density Up Selection	L	From P11-11, P11-12
13	Screen Selection	L	From P11-13, P11-14
14	Screen Selection	L	From P11-13, P11-14
15	Field Selection	L	From P11-15, P11-16
16	Field Selection	L	From P11-15, P11-16
17	Screen 1 LED	L	From J2-1
18	Grid Selection	L	From P11-18
19	Screen 2 LED	L	From J2-2
20	(No Connection)		
21	Grid Yes LED	L	From J2-3
22	(No Connection)		
23	Grid No LED	L	From J2-4
24	On/Off Selection	L	From P11-24
25	"mAs" LED	L	From J6-20
26	"+" Density LED	L	From J3-11
27	"AEC" Termination LED	L	From J6-4
28	"-" Density LED	L	From J3-10
29	AEC "On" LED	L	From J6-10
30	"--" Density LED	L	From P11-30
31	"GEN" Termination LED	L	From J6-12
32	Both Fields LED	L	From J2-7
33	Reset	L	From P11-33
34	Field One LED	L	From J2-6

## 7.0 DOCUMENTATION

Note: Signals marked with the "L" symbol are low-active signals.

## J2 ON/OFF, SCREEN, GRID AND FIELD SELECTIONS -- 61036B

61037A J2 pin out	Signal Name	Low-Active Signal	Source / Destination
1	Screen 1 LED	L	To P11-17
2	Screen 2 LED	L	To P11-19
3	Grid Yes LED	L	To P11-21
4	Grid No LED	L	To P11-23
5	Screen 1 / (L) Screen 2	see signal name	To J3-5
6	Field One LED	L	To P11-34
7	Both Fields LED	L	To P11-32
8	Grid No / (L) Grid Yes	see signal name	To J3-8
9	Field Selection		From P11-15, P11-16
10	Field Selection Reset	L	From J3-12
11	Field One / (L) Both Fields	see signal name	To J10-3
12	On/Off Selection	L	From P11-24
13	Grid Selection	L	From P11-18
14	Screen Selection	L	From P11-13, P11-14
15	+5 VDC		From F3-b
16	Power-on Reset (POR)		From J3-13
17	Ground when AEC is On		To J7-12
18	(No Connection)		
19	(No Connection)		
20	-12 VDC when AEC is On		To J3-23, J4-21, J5-24, J6-23, J7-18, J10-6
21	Ground		From P9-22
22	+12 VDC when AEC is On		To J3-24, J4-22, J5-25, J6-25, J7-15, J7-20, P9-1, J10-1, P11-5
23	+5 VDC when AEC is On		To J3-25, J4-25, J5-23, J6-22, J7- 11, P11-1, P11-9, P12-1, W2-c
24	+12 VDC		From F2-b
25	-12 VDC		From F1-b

7.0 DOCUMENTATION

Note: Signals marked with the "L" symbol are low-active signals.

J3 INPUT AMPLIFIER, ANTICIPATE, DENSITY, RESET -- 61039C

61037A J3 pin out	Signal Name	Low-Active Signal	Source / Destination
1	Compensation Voltage		From J4-23
2	Paddle Signal		From J10-8
3	Exposure Duration	L	From J6-11
4	Reset	L	From P11-33
5	Screen 1 / (L) Screen 2	see signal name	From J2-5
6	"++" Density LED	L	To P11-8
7	"--" Density LED	L	To P11-30
8	Grid No / (L) Grid Yes	see signal name	From J2-8
9	(No Connection)		
10	"-" Density LED	L	To P11-28
11	"+" Density LED	L	To P11-26
12	Field Selection Reset	L	To J2-10
13	Power-on Reset (POR)		To J2-16
14	Reset		To J6-3
15	Density Up	L	From P11-11, P11-12
16	AEC Exposure Stop	L	To J6-13
17	Density Down	L	From P11-10
18	(No Connection)		
19	(No Connection)		
20	Not used		To J4-19
21	Screen 1 / L Screen 2		To J4-20
22	Ground		From P9-22
23	-12 VDC when AEC is On		From J2-20
24	+12 VDC when AEC is On		From J2-22
25	+5 VDC when AEC is On		From J2-23

## 7.0 DOCUMENTATION

Note: Signals marked with the "L" symbol are low-active signals.

## J4 ANALOG CRV SELECTION -- 61047A

61037A J4 pin out	Signal Name	Low-Active Signal	Source / Destination
1	(not used)		From P9-3
2	(not used)		From P9-4
3	(not used)		From P9-7
4	(not used)		From P9-5
5	(not used)		From W1-b
6	(not used)		From P9-6
7	(No Connection)		
8	(No Connection)		
9	(not used)		From W2-b
10	(not used)		From J5-10
11	Interpolated kVp		From J5-11
12	Select "< 65kVp" CRV Potentiometers		From J5-12
13	(not used)		From J5-13
14	(not used)		From J5-14
15	Select "> 95kVp" CRV Potentiometers		From J5-15
16	Select "80-95kVp" CRV Potentiometers		From J5-16
17	Select "65-80kVp" CRV Potentiometers		From J5-17
18	(No Connection)		
19	Screen 1	<b>L</b>	From J3-20
20	Screen 2	<b>L</b>	From J3-21
21	-12 VDC when AEC is On		From J2-20
22	+12 VDC when AEC is On		From J2-22
23	Compensation Voltage		To J3-1
24	Ground		From P9-22
25	+5 VDC when AEC is On		From J2-23

7.0 DOCUMENTATION

Note: Signals marked with the "L" symbol are low-active signals.

J5 ANALOG kVp COMPUTER -- 61046A

61037A J5 pin out	Signal Name	Low-Active Signal	Source / Destination
1 TO 9	(No Connection)		
10	(not used)		To J4-10
11	Interpolated kVp		To J4-11
12	Select "< 65kVp" CRV Potentiometers		To J4-12
13	(not used)		To J4-13
14	(not used)		To J4-14
15	Select "> 95kVp" CRV Potentiometers		To J4-15
16	Select "80-95kVp" CRV Potentiometers		To J4-16
17	Select "65-80kVp" CRV Potentiometers		To J4-17
18	(not used)		From P9-15
19	+DC kVp	<b>L</b>	From J7-13
20	(not used)	<b>L</b>	From P9-18
21	(No Connection)		From J2-20
22	Ground		From P9-22
23	+5 VDC when AEC is On		From J2-23
24	-12 VDC when AEC is On		From J2-20
25	+12 VDC when AEC is On		From J2-22

7.0 DOCUMENTATION

Note: Signals marked with the "L" symbol are low-active signals.

J6 LOGIC -- 61040D

61037A J6 pin out	Signal Name	Low-Active Signal	Source / Destination
1	AEC Exposure Enable	L	To P9-24
2	(not used)		From J7-5 or P9-26
3	Reset		From J3-14
4	"AEC" Termination LED	L	To P1-27
5	(not used)		From P9-25
6	Exposure Start	L	From J7-6
7	(No Connection)		
8	(No Connection)		
9	Paddle Reset	L	To J10-2
10	AEC "On" LED	L	To P1-29
11	Exposure Duration	L	To P1-4, J3-3
12	"GEN" Termination LED	L	To P1-31
13	AEC Exposure Stop	L	From J3-16
14	(No Connection)		
15	AEC Stop (-)		To W3-b, J7-14
16	Paddle Interlock	L	From J10-5
17	(not used)		To P1-2
18	(not used)		To W3-c
19	(not used)		From J7-16 or P9-16
20	"mAs" LED	L	To P1-25
21	(not used)		From J7-17 or P9-20
22	+5 VDC when AEC is On		From J2-23
23	-12 VDC when AEC is On		From J2-20
24	Ground		From P9-22
25	+12 VDC when AEC is On		From J2-22

## 7.0 DOCUMENTATION

Note: Signals marked with the "L" symbol are low-active signals.

### J7 INTERFACE -- 61049D

61037A J7 pin out	Signal Name	Low-Active Signal	Source / Destination
1	(not used)		From P9-2
2	(not used)		From P9-8
3	(not used)		To P8-5
4	AEC Exposure Enable	L	From J6-1
5	(not used)		To J6-2
6	Exposure Start	L	To J6-6
7	DC kVp / Exposure Start		From P9-12
8	Ground when AEC is On		To P9-14
9	(No Connection)		
10	(not used)		To P9-23
11	+5 VDC when AEC is On		From J2-23
12	Ground when AEC is On		From J2-17
13	+DC kVp		To J5-19
14	(not used)		From J6-15
15	+12 VDC when AEC is On		From J2-22
16	(not used)		To J6-19
17	(not used)		To J6-21
18	-12 VDC when AEC is On		From J2-20
19	Ground		From P9-22
20	+12 VDC when AEC is On		From J2-22
21	+5 VDC		From F3-b
22	(not used)		To P8-1
23	+15 VDC		From F2-b
24	(not used)		To P8-2
25	-15 VDC		From F1-b

### P8 POWER SUPPLY CABLE - 75033

61037A P8 pin out	Signal Name	Low-Active Signal	Source / Destination
1	(not used)		To J7-22
2	(not used)		To J7-24
3	(No Connection)		
4	(not used)		To F1-a
5	(not used)		To J7-3
6	(not used)		To F2-a
7	(No Connection)		From P9-12
8	Ground		To J2-21, J3-22, J4-24, J5-22, J6-24, J7-19, P9-22, J10-7, J10-9, P11-3, P11-7, P12-3, W1-c
9	+5VDC		To F3-a, P9-19

## 7.0 DOCUMENTATION

Note: Signals marked with the "L" symbol are low-active signals.

## P9 GENERATOR INTERFACE LOGIC CABLE - 75031

61037A P9 pin out	Signal Name	Low-Active Signal	Source / Destination
1	+12 VDC when AEC is On		From J2-22
2	(not used)		To J7-1
3	(not used)		To J4-1
4	(not used)		To J4-2
5	(not used)		To J4-4
6	(not used)		To J4-6
7	(not used)		To J4-3
8	(not used)		To J7-2
9	AEC Exposure Enable		From J6-15
10	Exposure Start	<b>L</b>	To J6-6
11	(not used)		To W1-a
12	+DC kVp/Exposure Start		To J7-7
13	(not used)		From J7-13
14	(not used)		From J7-8
15	(not used)		To J5-18
16	(not used)		To J6-19
17	+15VDC		To F2-a
18	(not used)		To J5-20
19	+5VDC		From P8-9
20	(not used)		To J6-21
21	-15VDC		To F1-a
22	Ground		To J2-21, J3-22, J4-24, J5-22, J6-24, J7-19, P8-8, J10-7, J10-9, P11-3, P11-7, P12-3, W1-c
23	(not used)		From J7-10
24	Exposure Terminate		From J6-1
25	(not used)		To J6-5
26	(not used)		To J6-2, J7-5

## J10 INTERNAL PADDLE CABLE -- 75032

61037A J10 pin out	Signal Name	Low-Active Signal	Source / Destination
1	+12 VDC when AEC is On		From J2-22
2	Paddle Reset	<b>L</b>	From J6-9
3	Field One / (L) Both Fields	<b>see signal name</b>	From J2-11
4	(No Connection)		
5	Paddle Interlock	<b>L</b>	To J6-16
6	-12 VDC when AEC is On		From J2-20
7	Ground		From P9-22
8	Paddle Signal		To J3-2
9	+5VDC		To F3-a, P9-19