

Three-field Ionization Chamber
Calibration Procedure for Pre-Amplifier board 61116A
(Also valid for 61116C and 61116D)

The following adjustments apply to the calibration of a 61116A pre-amplifier board for a stationary 3-field ion chamber, e.g. for chest or table use.

Pre-amp Assembly	Description	Difference from 61116A
61116A	3-Field Pre-amp, Standard Gain	None
61116C	3-Field Pre-amp, High-Master-Gain	R11 = 50K ohm R13 = 1000 ohm
61116D	3-Field Pre-amp, Uneven Field Gains	R3 & R9 = 100K ohm R23 = 12K ohm

WARNING:

- This service manual is available in English only.
- If a customer's service provider requires a language other than English, it is the customer's responsibility to provide translation services.
- Do not attempt to service the equipment unless this service manual has been consulted and is understood.
- Failure to heed this warning may result in injury to the service provider, operator or patient from electric shock and mechanical or other hazards.

This document represents proprietary information originated by Advanced Instrument Development, Inc. and which shall not be disclosed or utilized in any manner detrimental to the company's business.

The procedure assumes that the installation of the Automatic Exposure Control (AEC) is complete and that the AEC and x-ray generator are in proper working condition. After making the necessary interconnections between the ion chamber and the AEC, power up the system.

The 61116A pre-amplifier board can be configured to operate with several different AEC systems. If specified at the time of purchase, the ion chamber will be delivered with the pre-amplifier board already configured for a particular application. To reconfigure an ion chamber for a different configuration, see the section on Ion Chamber Inputs and Output and the section on Specific Configurations at the end of this document.

Calibration/Test Set Up:

Select the center field of the ion chamber. Set the generator for 100 kVp and maximum backup time. For 100 kVp use 8 to 10 inches (20 to 25 cm) of water or plastic for a phantom. Metals such as copper, aluminum or lead are not suitable for use as phantoms. Make sure the phantom is homogeneous and completely covers all fields equally. Center the x-ray beam on the center field. Collimate the x-ray beam so that it completely covers all three fields but does not extend beyond the limits of the phantom.

Adjustment Potentiometers:

All necessary adjustment potentiometers are accessible through the pre-amp chassis cover. There is no need to open the pre-amp cover during normal calibration procedures.

Master Gain Adjustment (61116A R11):

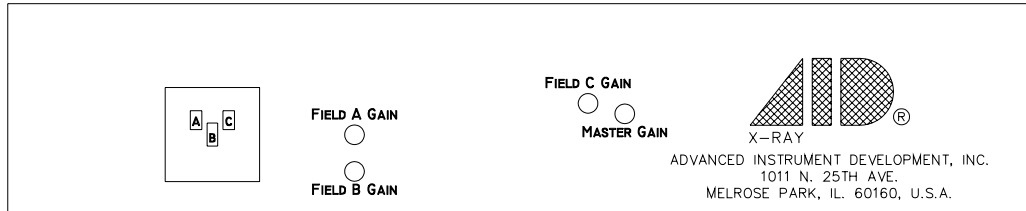

Typically, the chamber gain adjustment is the only adjustment needed when installing a ICX series ion chamber. Use the chamber gain adjustment to match the overall chamber sensitivity to that of the other stationary chambers connected to the system. Note that the chamber gain adjustment is a multi-turn potentiometer. A clockwise adjustment to the master gain potentiometer will increase the sensitivity of the chamber, causing the length of the exposure (mAs) to decrease.

Make exposures and process the films. Adjust the chamber gain for the desired optical density. Make the chamber gain adjustment for each stationary chamber being installed.

Field Balance Check:

Using the AEC post-exposure mAs display or other calibrated mAs meter check the individual fields to see that they are balanced, that is, that they produce the same mAs reading. If mAs readings are not stable from exposure to exposure for an individual field, then it will be necessary to expose films and make these adjustments based upon optical density.

If necessary, adjust the individual gain potentiometers to balance the outputs to give the same mAs reading for each field selected individually. Note that individual gain adjustments are multi-turn potentiometers. A clockwise adjustment to a field gain potentiometer will increase the sensitivity of that field, causing the length of the exposure (mAs) to decrease.

Ionization Chamber Pin-outs:

61116A Pre-amp Board Pin-out	61116A Pre-amp Chassis Wire Color	Function	9-Pin Sub-D Pin-Out
no connection	NONE	none	1
2	RED	FIELD 2 SELECT	2
3	ORANGE	FIELD 1 SELECT	3
4	YELLOW	RESET	4
5	GREEN	OUTPUT	5
6	BLUE	FIELD 3 SELECT	6
7	VIOLET	-15VDC	7
8	GRAY	+15VDC	8
9	WHITE	GROUND	9

Acceptable Power Supply Ranges for 61116A Pre-amp:

Supply Voltage	Measurement Point	Acceptable Range
+12VDC Pos. Input Supply Voltage	61116A pin 8	From +11.4VDC to +15.75VDC
-12VDC Neg. Input Supply Voltage	61116A pin 7	From -11.4VDC to -15.75VDC
+5VDC Regulated on board	61116A C31 (positive lead)	From +4.7VDC to +5.3VDC
-5VDC Regulated on board	61116A C28 (negative lead)	From -4.7VDC to -5.3VDC
+75VDC Internal Bias Voltage Regulated on board	61116A C6 at the cathode of D1	From +65VDC to +85VDC

Ionization Chamber Inputs and Output:

Signal	Jumper	Comments
Positive Supply Voltage Range	None	+11.4VDC to +15.75VDC less than 85 mA.
Negative Supply Voltage Range	None	-11.4VDC to -15.75VDC less than 15 mA.
Reset1 (Exposure Duration)	None	No jumper selection is required. Pulling this line to ground (<3VDC) or driving this line high (>16VDC) beginning at exposure start and lasting for the entire duration of the exposure allows the integrator to operate.
Negative Output	W1 = 1-2	Time integrated signal ramping from 0VDC to a maximum of at least 80% of the supply voltage (-9.6VDC for -12VDC supply). The slope of this signal is directly proportional to the amount of x-ray flux received.
Positive Output	W1 = 2-3	Time integrated signal ramping from 0VDC to a maximum of at least 80% of the supply voltage (+9.6VDC for +12VDC supply). The slope of this signal is directly proportional to the amount of x-ray flux received.
Low-active Field Selects	W2, W3 and W4 = 1-2 & 3-4	Low-active: Pulling the field select lines to ground (0VDC) will select the field.
High-active Field Selects	W2, W3 and W4 = 2-3 & 4-5	High-active: Driving the field select lines high (+12VDC to +24VDC) will select the field.
Field Configuration A-B-C = 1-2-3	W5 = 1-3 & 2-4 and W6 = 1-2 & 3-4	Field selects 1, 2 and 3 select left (A), center (B) and right (C), respectively, as viewed from the x-ray tube-side of the ion chamber.
Field Configuration A-B-C = 2-1-3	W5 = 1-2 & 3-4 and W6 = 1-2 & 3-4	Field selects 2, 1 and 3 select left (A), center (B) and right (C), respectively, as viewed from the x-ray tube-side of the ion chamber.
Field Configuration A-B-C = 3-1-2	W5 = 1-2 & 3-4 and W6 = 1-3 & 2-4	Field selects 3, 1 and 2 select left (A), center (B) and right (C), respectively, as viewed from the x-ray tube-side of the ion chamber.
Field Configuration A-B-C = 3-2-1	W5 = 1-3 & 2-4 and W6 = 1-3 & 2-4	Field selects 3, 2 and 1 select left (A), center (B) and right (C), respectively, as viewed from the x-ray tube-side of the ion chamber.

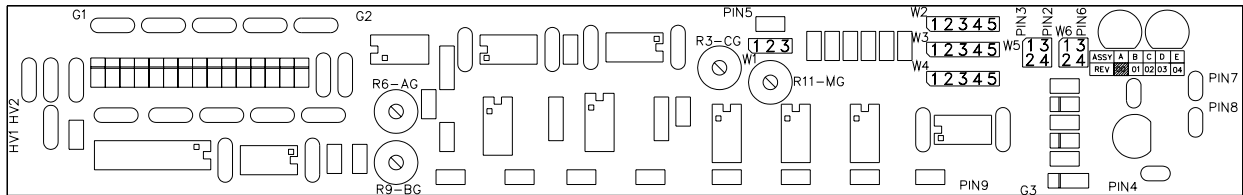

¹ If the Reset signal is not an open-collector signal between exposures, it may be necessary to insert a diode in-series with this signal to allow the pre-amp to integrate only during exposures.

Phone: (630) 271-9729

www.aidxray.com

Fax: (630) 271-9995

Specific Configurations:

Unless specified otherwise, ICX ion chambers are delivered with an AID compatible jumper configuration. AID compatible means that the input and output signals will interface with Advanced Instrument Development, Inc's Expos-AID™ Automatic Exposure Control. This same configuration will also interface with Acoma, Control-X, CPI, Del Medical (Gendex), Electromed (EMD, Triton), OEC, Quantum Medical Imaging, Sedecal (Innerscan), Summit Industries, etc.

AID Compatible jumper configuration:

Jumper	Position	Function
61116A W1	2-3	positive output signal
61116A W2, W3 and W4	1-2 & 3-4	low-active field select
61116A W5 and 61116A W6	1-2 & 3-4 and 1-2 & 3-4	A-B-C = 2-1-3

Alternate configurations are listed below.

GE, Fischer, Varian Compatible jumper configuration:

Jumper	Position	Function
61116A W1	2-3	positive output signal
61116A W2, W3 and W4	2-3 & 4-5	high-active field select
61116A W5 and 61116A W6	1-3 & 2-4 and 1-2 & 3-4	A-B-C = 1-2-3

Picker Compatible jumper configuration:

Jumper	Position	Function
61116A W1	1-2	negative output signal
61116A W2, W3 and W4	1-2 & 3-4	low-active field select
61116A W5 and 61116A W6	1-2 & 3-4 and 1-2 & 3-4	A-B-C = 2-1-3

Trex Medical - Continental Compatible jumper configuration:

Jumper	Position	Function
61116A W1	2-3	positive output signal
61116A W2, W3 and W4	1-2 & 3-4	low-active field select
61116A W5 and 61116A W6	1-3 & 2-4 and 1-2 & 3-4	A-B-C = 1-2-3

Trex Medical - Bennett, Keithley, Ratheon, Xonics Compatible jumper configuration:

Jumper	Position	Function
61116A W1	1-2	negative output signal
61116A W2, W3 and W4	1-2 & 3-4	low-active field select
61116A W5 and 61116A W6	1-3 & 2-4 and 1-2 & 3-4	A-B-C = 1-2-3

GTR Labs Compatible jumper configuration:

Jumper	Position	Function
61116A W1	2-3	positive output signal
61116A W2, W3 and W4	1-2 & 3-4	low-active field select
61116A W5 and 61116A W6	1-2 & 3-4 and 1-3 & 2-4	A-B-C = 3-1-2 (= GTR Labs fields 1-2-3)

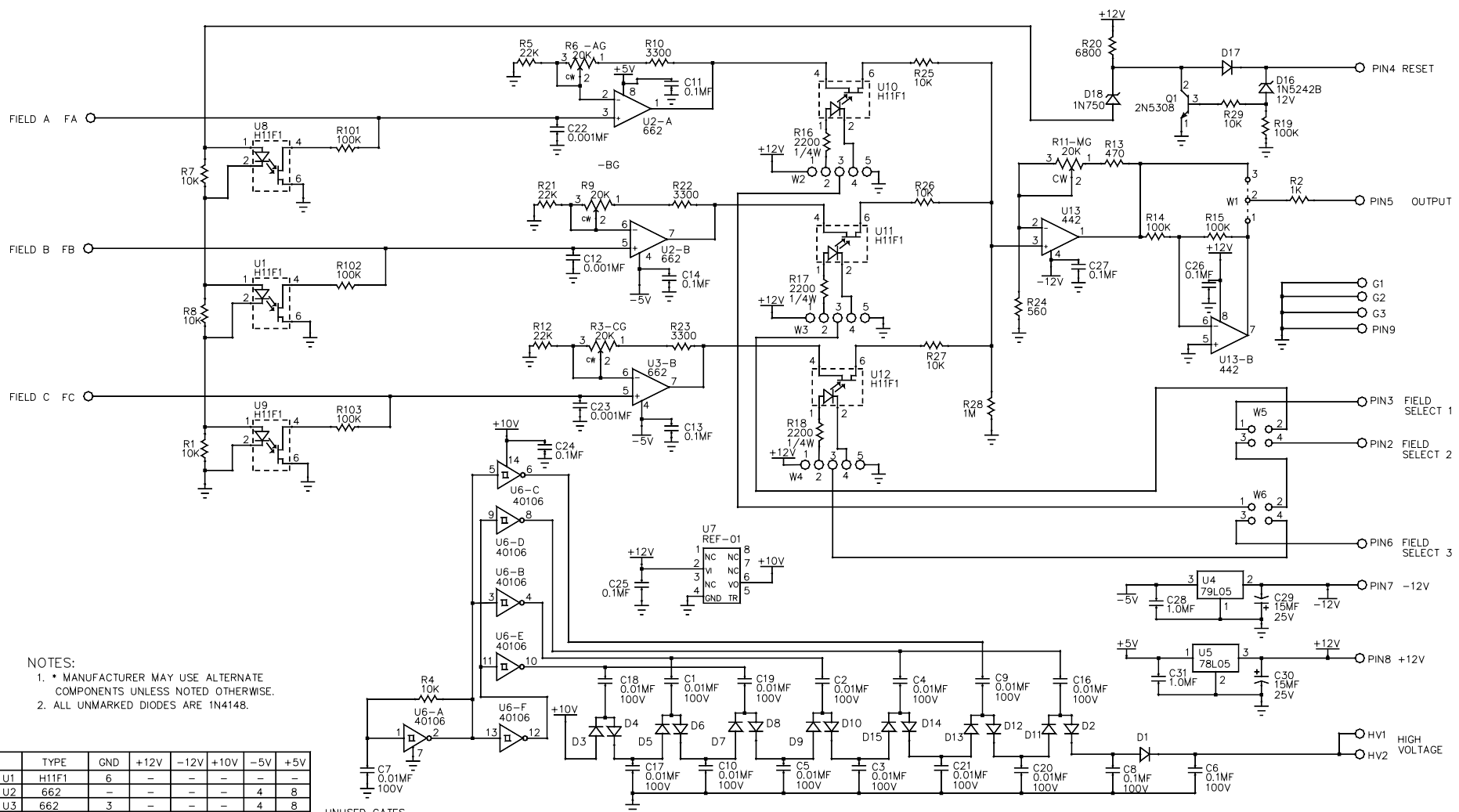

NOTES:
 1. * MANUFACTURER MAY USE ALTERNATE COMPONENTS UNLESS NOTED OTHERWISE.
 2. ALL UNMARKED DIODES ARE 1N4148.

	TYPE	GND	+12V	-12V	+10V	-5V	+5V
U1	H11F1	6	-	-	-	-	8
U2	662	-	-	-	-	4	8
U3	662	3	-	-	-	4	8
U4	79L05	1	-	2	-	3	-
U5	78L05	2	3	-	-	-	1
U6	40106	7	-	-	14	-	-
U7	REF-01	4	2	-	6	-	-
U8	H11F1	6	-	-	-	-	-
U9	H11F1	2,6	-	-	-	-	-
U10	H11F1	-	-	-	-	-	-
U11	H11F1	-	-	-	-	-	-
U12	H11F1	-	-	-	-	-	-
U13	1458	5	8	4	-	-	-

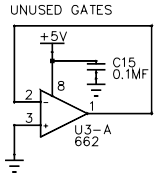

REV.	ECN NO.	DATE	REVISIONS	BY
05	1752	22SEP98	U13 WAS 1458	TRW
04	1692	25MAR98	SEE COMPONENT LAYOUT	BRP
03	1666	07JAN98	D16 FROM 1N4745 TO 1N5242B	JC
03	1666	07JAN98	C8 & C9 WERE 0.01MFD 100VDC R16, R17, & R18 WERE 1K, 1/4W	JC
02	1552	18FEB97	SEE COMPONENT LAYOUT	JC
01	1588	24JUN97	ELIMINATE W7	JC

DO NOT SCALE			
UNLESS SPECIFIED OTHERWISE: DIMENSIONS ARE IN INCHES: FRACTIONS DECIMALS ANGLES ±1/64 ±0.010 ±1°			
SCALE	NONE	DRAWN BY	JC
MATERIAL		CHECKED BY	JC
FINISH		APPROVED BY	05MAY97
DATE			

ADVANCED INSTRUMENT DEVELOPMENT, INC.
 1011 N. 25TH AVE.
 MELROSE PARK, IL. 60160

3-FIELD PRE-AMP BD.

THIS DRAWING REPRESENTS PROPRIETARY AND CONFIDENTIAL INFORMATION ORIGINATED BY ADVANCED INSTRUMENT DEVELOPMENT, INC. AND WHICH SHALL NOT BE DISCLOSED OR UTILIZED IN ANY MANNER DETRIMENTAL TO THE COMPANY'S BUSINESS.