

Single Spot Ionization Chamber
Calibration Instructions (p/n 69277 Rev. C)
61125A Pre-amplifier

The following adjustment applies to the calibration of a 61125A pre-amplifier board for a stationary spot-field ion chamber. (Also valid for 61125B and 61125C)

Pre-amp Assembly	Description	Difference from 61125A
61125A	3-Field Pre-amp, Standard Gain, Side-Turn Pot	None
61125B	3-Field Pre-amp, Standard Gain, Top-Turn Pot	R4 is top-turn pot
61125C	3-Field Pre-amp, High Gain, Top-Turn Pot	C14 = 220PF R4 is top-turn pot R6 = 680 ohm R7 = 6800 ohm

WARNING:

- This service manual is available in English only.
- If a customer's service provider requires a language other than English, it is the customer's responsibility to provide translation services.
- Do not attempt to service the equipment unless this service manual has been consulted and is understood.
- Failure to heed this warning may result in injury to the service provider, operator or patient from electric shock and mechanical or other hazards.

This document represents proprietary information originated by Advanced Instrument Development, Inc. and which shall not be disclosed or utilized in any manner detrimental to the company's business.

The procedure assumes that the installation of the Automatic Exposure Control (AEC) is complete and that the AEC and x-ray generator are in proper working condition. After making the necessary interconnections between the ion chamber and the AEC, power up the system.

The 61125A pre-amplifier board can be configured to operate with several different AEC systems. If specified at the time of purchase, the ion chamber will be delivered with the pre-amplifier board already configured for a particular application. To reconfigure an ion chamber for a different configuration, see the section on Ion Chamber Inputs and Output.

Calibration/Test Set Up:

Set the generator for 100 kVp and maximum backup time. For 100 kVp use 8 to 10 inches (20 to 25 cm) of water or plastic for a phantom. Metals such as copper, aluminum or lead are not suitable for use as phantoms. Make sure the phantom is homogeneous and completely covers the ion chamber field. Center the x-ray beam on the ion chamber field. Collimate the x-ray beam so that it completely covers the ion chamber field but does not extend beyond the limits of the phantom.

Chamber Gain Adjustment (61125A R4)

Typically, the chamber gain adjustment is the only adjustment needed when installing an ICX series ion chamber. Use the chamber gain adjustment to match the overall chamber sensitivity to that of the other stationary chambers connected to the system. Note that the chamber gain adjustment is a multi-turn potentiometer. A clockwise adjustment to the chamber gain potentiometer will increase the sensitivity of the chamber, causing the length of the exposure (mAs) to decrease.

Make exposures and process the films. Adjust the chamber gain for the desired optical density. Make the chamber gain adjustment for each stationary chamber being installed.

Ion Chamber Inputs and Output:

61125A Pre-amplifier 9-Pin Sub-d Pin-outs			
1	no connection	6	no connection
2	no connection	7	-12VDC
3	no connection	8	+12VDC
4	Reset	9	Ground
5	Output		

61125A Pre-amplifier GE Compatible 14-Pin Amp M Series Pin-outs		
14-Pin Connector	61125A Pin-out	Function
A	R	RESET (Start Integration)
B	+V	+12VDC
C	-	no connection*
D	O	OUTPUT
E	-V	-12VDC
F	G	GROUND*
H, J	-	no connection
K	G2	SHIELD
L	-	no connection
M	-	no connection**
N, P, R	-	no connection

* Unlike the GE Model 88 spot film device the ICX series ion chambers use the same ground connection (14-pin connector pin F) for signal ground, relay ground and chassis ground, therefore no connection is required at the 14-pin connector pin C.

** Unlike the GE Model 88 spot film device the ICX series ion chambers generate their bias voltage internal to the pre-amplifier, therefore no connection is required at the 14-pin connector pin M.

NOTE: Cable wire colors do not match those inside the pre-amp chassis. Cable pin-out details are available on-line at <http://www.aidxray.com> or by contacting Advanced Instrument Development, Inc.

Acceptable Power Supply Ranges for 61125A Pre-amp:

Supply Voltage	Measurement Point	Acceptable Range
+12VDC Pos. Input Supply Voltage	61125A pin P12V	From +11.4VDC to +12.6VDC
-12VDC Neg. Input Supply Voltage	61125A pin N12V	From -11.4VDC to -12.6VDC
+5VDC Regulated on board	61125A C1 (positive lead)	From +4.7VDC to +5.3VDC
+75VDC Internal Bias Voltage Regulated on board	61125A C26 at the cathode of D33	From +65VDC to +85VDC

Signal	Jumper	Comments
Positive Supply Voltage Range	None	+11.4VDC to +15.75VDC less than 85 Ma.
Negative Supply Voltage Range	None	-11.4VDC to -15.75VDC less than 15 Ma.
Low-Active Reset (Start Integration)	W3 = 2-3 & 4-5	Pulling this line to ground (< +3VDC) beginning at exposure start and lasting for the entire duration of the exposure allows the integrator to operate.
High-Active Reset (Start Integration)	W3 = 1-2 & 3-4	Driving this line high (\geq +12VDC) beginning at exposure start and lasting for the entire duration of the exposure allows the integrator to operate.
Anticipate Circuit Off	W2 = 2-3	Typically this circuit is not used.
Anticipate Circuit On	W2 = 1-2	This circuit compensates for cable capacitance during extremely short exposures.
Negative Output	W1 = 1-2	Time integrated signal ramping from 0VDC to a maximum of at least 80% of the supply voltage (-9.6VDC for -12VDC supply). The slope of this signal is directly proportional to the amount of x-ray flux received.
Positive Output	W1 = 2-3	Time integrated signal ramping from 0VDC to a maximum of at least 80% of the supply voltage (+9.6VDC for +12VDC supply). The slope of this signal is directly proportional to the amount of x-ray flux received.

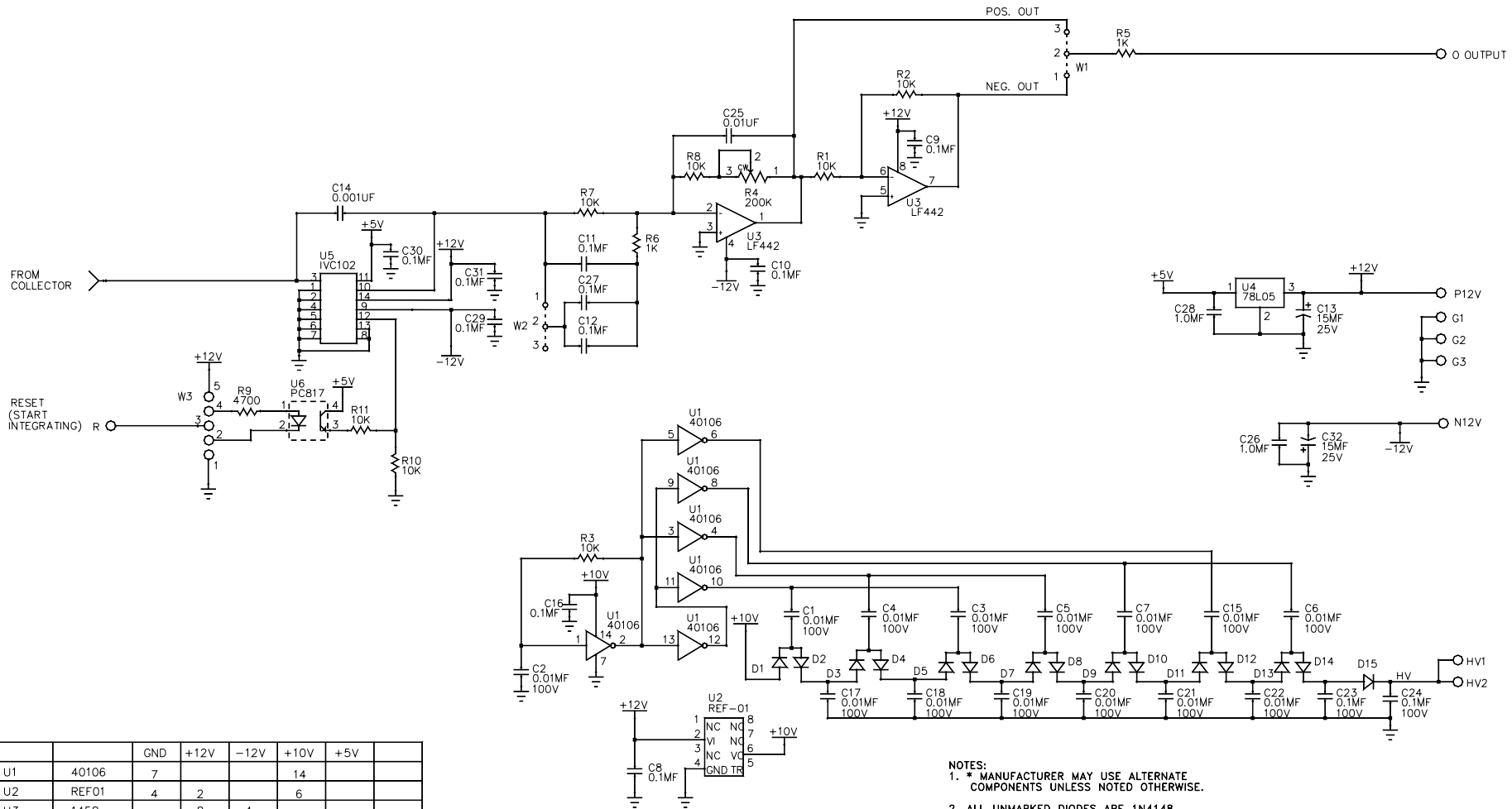

		GND	+12V	-12V	+10V	+5V	
U1	40106	7			14		
U2	REF01	4	2		6		
U3	1458		8	4			
U4	78L05	2	3			1	
U5	IVC102	1,2,4,5,6,7,8,13	14	9		11	
U6	PC817	2,6					

- NOTES:
 1. * MANUFACTURER MAY USE ALTERNATE COMPONENTS UNLESS NOTED OTHERWISE.
 2. ALL UNMARKED DIODES ARE 1N4148.

REV.	ECN NO.	DATE	REVISIONS	BY

DO NOT SCALE			
UNLESS SPECIFIED OTHERWISE; DIMENSIONS ARE IN INCHES. FRACTIONS DECIMALS ANGLES ±1/64 ±0.010 ±1°			
SCALE	NONE	DRAWN BY	CJL
MATERIAL		CHECKED BY	4MAR98
FINISH		APPROVED BY	
THIS DRAWING REPRESENTS PROPRIETARY AND CONFIDENTIAL INFORMATION ORIGINATED BY ADVANCED INSTRUMENT DEVELOPMENT, INC. AND WHICH SHALL NOT BE DISCLOSED OR UTILIZED IN ANY MANNER DETRIMENTAL TO THE COMPANY'S BUSINESS.			
USED ON	ICX SERIES	NEXT ASSY.	
DRAWING NO.	61125A	REV.	00

ADVANCED INSTRUMENT DEVELOPMENT, INC.
 1011 N. 25TH AVE.
 MELROSE PARK, IL. 60160



SPOT FILM PRE-AMP BOARD