

Three-field Ionization Chamber Calibration Procedure
 for
 Pre-Amplifier board assembly 61135A
 (Also valid for the pre-amp assemblies listed below)

Pre-amp Assembly	Description	Difference from 61135A
61135A	3-Field Pre-amp, Standard Gain	None
61135B	3-Field Pre-amp, High-Field-Gain	R5, R9, R13 = 50K ohm R20 = 1500 ohm
61135C	3-Field Pre-amp, High-Master-Gain	R20 = 1500 ohm R21 = 2200 ohm R22 = 50K ohm
61135D	3-Field Pre-amp, Standard Gain	Side-Turn Pots
61135F	3-Field Pre-amp, Low-Active Field B selection forces Field C selection	Added D16 R9, R13 = 100K ohm R10 = 12K ohm
61135G	3-Field Pre-amp, High-Field-Gain, High-Master-Gain	R5, R9, R13, R22 = 50K ohm R20 = 1800 ohm R21 = 2200 ohm
61135J	3-Field Pre-amp, High-Master-Gain	R20 = 1500 ohm R21 = 2200 ohm R22 = 50K ohm Side-Turn Pots
61135K	3-Field Pre-amp, High-Active Field B selection forces Field C selection	Added D16 R9, R13 = 100K ohm R10 = 12K ohm
61135L	3-Field Pre-amp, GEMS Gain	R20 = 1800 ohm R21 = 1500 ohm R27 = 1000 ohm Side-Turn Pots
61135N	3-Field Pre-amp, High-Master-Gain	R20 = 1000 ohm R21 = 2200 ohm R22 = 50K ohm

WARNING:

- Do not attempt to service the equipment unless this service manual has been consulted and is understood.
- Failure to heed this warning may result in injury to the service provider, operator or patient from electric shock and mechanical or other hazards.

Note: When working with the pre-amplifier assembly it is important that electrostatic discharge (ESD) prevention techniques be observed. Before touching the pre-amp assembly, attach an ESD wrist strap to yourself. Be sure to ground yourself and the ion chamber frame to dissipate static charges.

Note: The pre-amp assembly is a very delicate and sensitive device. It is important to keep it as clean as possible. Wash and dry your hands thoroughly before working with it and, when possible, use unpowdered latex or cotton gloves. Take care to touch the pre-amp board as little as possible. Take extra care to avoid touching the three air-mounted field inputs. Oils from your fingers on the air-mounts or their components can cause performance degradation.

This document represents proprietary information originated by Advanced Instrument Development, Inc. and which shall not be disclosed or utilized in any manner detrimental to the company's business.

The following adjustments apply to the calibration of a 61135A pre-amplifier board for a stationary 3-field ion chamber, e.g. for chest or table use.

This document describes the calibration of standard "V" or "Y" pattern ion chambers commonly used in medical radiographic equipment, with sensing fields located at the lung and center (spine) positions. The operator selects the field(s) desired, and positions the anatomy of interest in front of the selected field(s). Note that for "Y" pattern ion chambers the two lung fields act together as field "A".

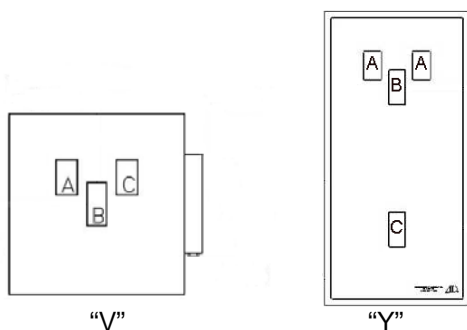

The procedure assumes that the installation of the Automatic Exposure Control (AEC) is complete and that the AEC and x-ray generator are in proper working condition. After making the necessary interconnections between the ion chamber and the AEC, power up the system.

The 61135A pre-amplifier board can be configured to operate with several different AEC systems. If specified at the time of purchase, the ion chamber will be delivered with the pre-amplifier board already configured for a particular application. To reconfigure an ion chamber for a different configuration, see the section on Ion Chamber Inputs and Output and the section on Specific Configurations at the end of this document.

Calibration/Test Set Up:

Select the center field of the ion chamber. Set the generator for 100 kVp and maximum backup time. For 100 kVp use 8 to 10 inches (20 to 25 cm) of water or plastic for a phantom. Metals such as copper, aluminum or lead are not suitable for use as phantoms. Make sure the phantom is homogeneous and completely covers all fields equally. Center the x-ray beam on the center field. Collimate the x-ray beam so that it completely covers all three fields but does not extend beyond the limits of the phantom.

Adjustment Potentiometers:

All necessary adjustment potentiometers are accessible through the pre-amp chassis cover. There is no need to open the pre-amp cover during normal calibration procedures.

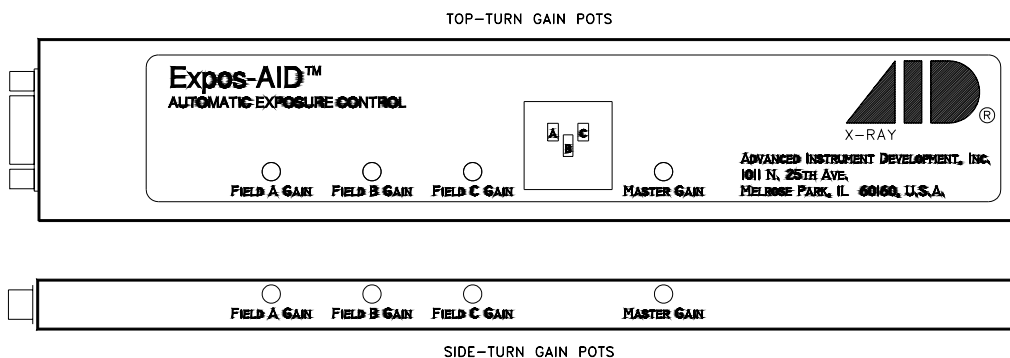

Master Gain Adjustment:

Typically, the chamber gain adjustment is the only adjustment needed when installing a ICX series ion chamber. Use the chamber gain adjustment to match the overall chamber sensitivity to that of the other stationary chambers connected to the system. Note that the chamber gain adjustment is a multi-turn potentiometer. A clockwise adjustment to the master gain potentiometer will increase the sensitivity of the chamber, causing the length of the exposure (mAs) to decrease.

Make exposures and process the films. Adjust the chamber gain for the desired optical density. Make the chamber gain adjustment for each stationary chamber being installed.

Field Balance Check:

Using the AEC post-exposure mAs display or other calibrated mAs meter check the individual fields to see that they are balanced, that is, that they produce the same mAs reading. If mAs readings are not stable from exposure to exposure for an individual field, then it will be necessary to expose films and make these adjustments based upon optical density.

If necessary, adjust the individual gain potentiometers to balance the outputs to give the same mAs reading for each field selected individually. Note that individual gain adjustments are multi-turn potentiometers. A clockwise adjustment to a field gain potentiometer will increase the sensitivity of that field, causing the length of the exposure (mAs) to decrease.

Ionization Chamber Pin-outs:

61135A Pre-amp Board Pin-out	Function	9-Pin Sub-D Pin-Out
N/C	NONE	1
2	FIELD 2 SELECT	2
3	FIELD 1 SELECT	3
4	RESET	4
5	OUTPUT	5
6	FIELD 3 SELECT	6
7	NEGATIVE SUPPLY	7
8	POSITIVE SUPPLY	8
9	GROUND	9

NOTE: Cable wire colors do not match those inside the pre-amp chassis. Cable pin-out details are available on-line at <http://www.aidxray.com> or by contacting Advanced Instrument Development, Inc.

Acceptable Power Supply Ranges for 61135A Pre-amp:

Supply Voltage	Measurement Point	Acceptable Range
+12VDC Pos. Input Supply Voltage	61135A pin 8	From +11.4VDC to +15.8VDC
-12VDC Neg. Input Supply Voltage	61135A pin 7	From -11.4VDC to -15.8VDC
+5VDC Regulated on board	61135A C12 (positive lead)	From +4.7VDC to +5.3VDC
+75VDC Internal Bias Voltage Regulated on board	61135A C35 at the cathode of D15	From +65VDC to +85VDC

Specific Configurations:

Unless specified otherwise, ICX ion chambers are delivered with an AID compatible jumper configuration. AID compatible means that the input and output signals will interface with Advanced Instrument Development, Inc's Expos-AID™ Automatic Exposure Control. This same configuration will also interface with Acoma, Control-X, CPI, Del Medical (Gendex), Electromed (EMD, Triton), OEC, Quantum Medical Imaging, Sedecal (Innerscan), Summit Industries, etc.

AID Compatible jumper configuration:

Jumper	Position	Function
61135A W1	1-2 & 3-4	low-active reset
61135A W2, W3 and W4	1-2 & 3-4	low-active field select
61135A W5 and 61135A W6	1-2 & 3-4 and 1-2 & 3-4	A-B-C = 2-1-3
61135A W7	2-3	positive output signal

Alternate configurations are listed below.

GE, Fischer, Varian Compatible jumper configuration:

Jumper	Position	Function
61135A W1	2-3 & 4-5	high-active reset
61135A W2, W3 and W4	2-3 & 4-5	high-active field select
61135A W5 and 61135A W6	1-3 & 2-4 and 1-2 & 3-4	A-B-C = 1-2-3
61135A W7	2-3	positive output signal

Picker Compatible jumper configuration:

Jumper	Position	Function
61135A W1	1-2 & 3-4	low-active reset
61135A W2, W3 and W4	1-2 & 3-4	low-active field select
61135A W5 and 61135A W6	1-2 & 3-4 and 1-2 & 3-4	A-B-C = 2-1-3
61135A W7	1-2	negative output signal

Trex Medical - Continental, Keithley, Ratheon, Xonics Compatible jumper configuration:

Jumper	Position	Function
61135A W1	1-2 & 3-4	low-active reset
61135A W2, W3 and W4	1-2 & 3-4	low-active field select
61135A W5 and 61135A W6	1-3 & 2-4 and 1-2 & 3-4	A-B-C = 1-2-3
61135A W7	2-3	positive output signal

Trex Medical - Bennett Compatible jumper configuration:

Jumper	Position	Function
61135A W1	1-2 & 3-4	low-active reset
61135A W2, W3 and W4	1-2 & 3-4	low-active field select
61135A W5 and 61135A W6	1-3 & 2-4 and 1-2 & 3-4	A-B-C = 1-2-3
61135A W7	1-2	negative output signal

GTR Labs Compatible jumper configuration:

Jumper	Position	Function
61135A W1	1-2 & 3-4	low-active reset
61135A W2, W3 and W4	1-2 & 3-4	low-active field select
61135A W5 and 61135A W6	1-2 & 3-4 and 1-3 & 2-4	A-B-C = 3-1-2 (= GTR Labs fields 1-2-3)
61135A W7	2-3	positive output signal

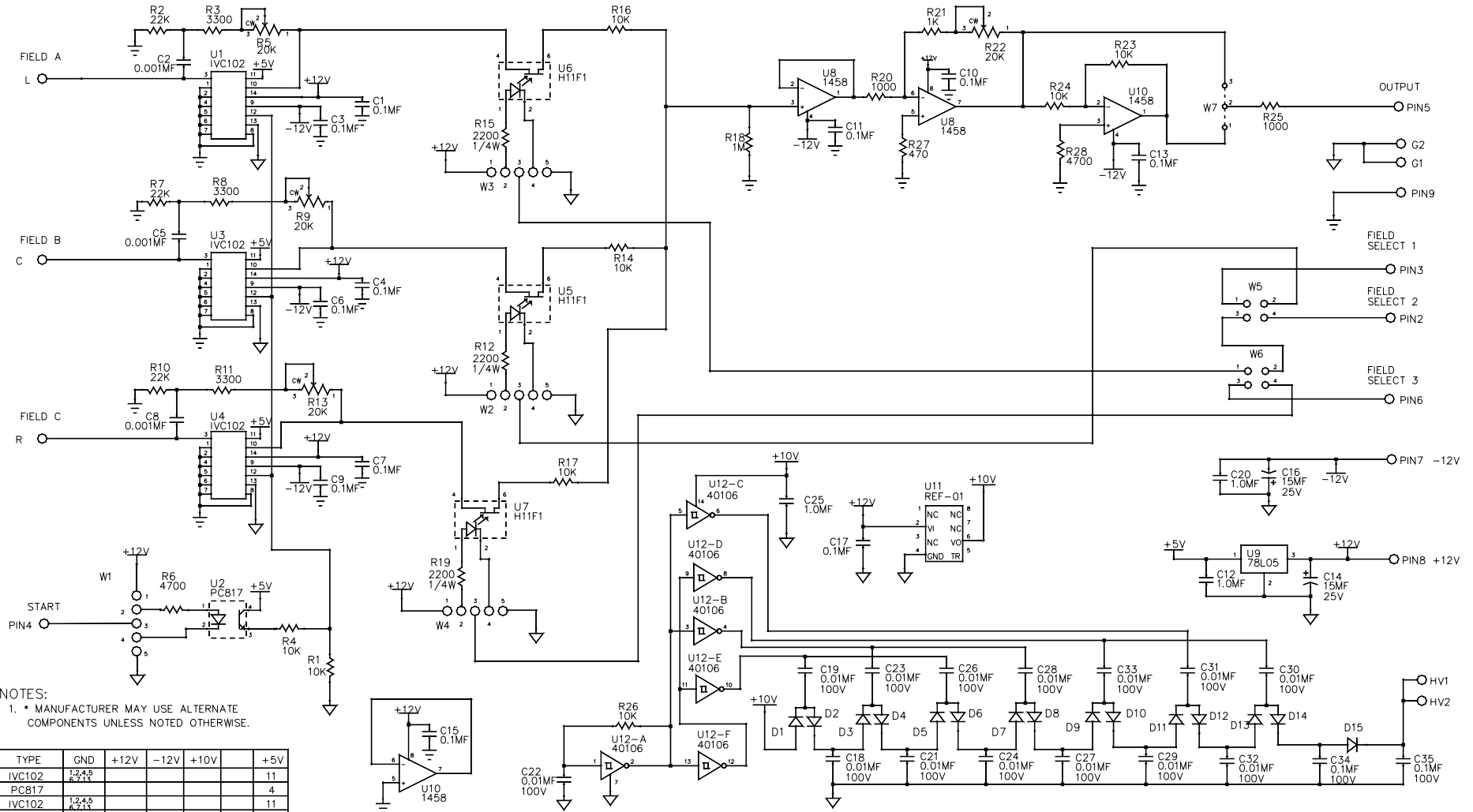

NOTES:
 1. * MANUFACTURER MAY USE ALTERNATE COMPONENTS UNLESS NOTED OTHERWISE.

	TYPE	GND	+12V	-12V	+10V	+5V
U1	IVC102	12,4,5,6,7,8				11
U2	PC817					4
U3	IVC102	12,4,5,6,7,8				11
U4	IVC102	12,4,5,6,7,8				11
U5	H11F1					
U6	H11F1					
U7	H11F1					
U8	1458	5	8	4		1
U9	78L05	2	3			
U10	1458	3,5	8	4		
U11	REF-01	4	2		6	
U12	40106	7			14	

REV.	ECN NO.	DATE	REVISIONS	BY
06	2170	02MAR04	SEE LAYOUT	BRP
05	2047	03MAY02	SEE LAYOUT	BRP
04	2047	03MAY02	SEE LAYOUT	BRP
03	2018	08NOV01	SEE LAYOUT	BRP
02	2018	08NOV01	SAME AS 61135X EXCEPT: R5,R9,R13=20K T-T POTS, R20 & R21=1K, R27=470	BRP

DO NOT SCALE
 UNLESS SPECIFIED OTHERWISE;
 DIMENSIONS ARE IN INCHES.
 FRACTIONS DECIMALS ANGLES
 ±1/64 ±0.010 ±1°
 SCALE NONE DRAWN BY C.J.L. DATE 9NOV98
 CHECKED BY APPROVED BY

ADVANCED INSTRUMENT DEVELOPMENT, INC.
 1011 N. 25TH AVE.
 MELROSE PARK, IL. 60160

75 VOLT BIAS
 3-FIELD PRE-AMP BD.

THIS DRAWING REPRESENTS PROPRIETARY AND CONFIDENTIAL INFORMATION ORIGINATED BY ADVANCED INSTRUMENT DEVELOPMENT, INC. AND WHICH SHALL NOT BE DISCLOSED OR UTILIZED IN ANY MANNER DETRIMENTAL TO THE COMPANY'S BUSINESS.
 USED ON IXCX SERIES NEXT ASSY. DRAWING NO. 61135A REV. 06