

Three-field Ionization Chamber  
 Calibration Procedure  
 for  
 The 61154 Pre-Amplifier Board Assemblies

The following adjustments apply to the calibration of a 61154A pre-amplifier board for a stationary 3-field ion chamber, e.g. for chest or table use. (Also valid for 61154C, 61154G, 61154J, 61154L, 61154N, 61154S and 61154T)

Pre-amp Assembly	Description	Difference from 61154A
61154A	Calculated Gain Range = 1.0 to 21.0	None
61154C	Calculated Gain Range = 1.47 to 34.8	R24 = 1500 ohm R31 = 2200 ohm R4 = 50K ohm
61154G	Calculated Gain Range = 1.22 to 29.0	R1, R2, R3, R4 = 50K ohm R24 = 1800 ohm R31 = 2200 ohm
61154J	Calculated Gain Range = 1.47 to 34.8	R24 = 1500 ohm R31 = 2200 ohm R4 = 50K ohm Side-Turn Pots
61154L	Calculated Gain Range = 0.83 to 11.94	R24 = 1800 ohm R31 = 1500 ohm Side-Turn Pots
61154N	Calculated Gain Range = 2.2 to 52.2	R31 = 2200 ohm R4 = 50K ohm
61154S	Calculated Gain Range = 2.68 to 63.7	R 4 = 50K ohm R24 = 820 ohm R31 = 2200 ohm Top-Turn Pots
61154T	Calculated Gain Range = 2.68 to 63.7	R 4 = 50K ohm R24 = 820 ohm R31 = 2200 ohm Side-Turn Pots

**WARNING:**

- Do not attempt to service the equipment unless this service manual has been consulted and is understood.
- Failure to heed this warning may result in injury to the service provider, operator or patient from electric shock and mechanical or other hazards.

Note: When working with the pre-amplifier assembly it is important that electrostatic discharge (ESD) prevention techniques be observed. Before touching the pre-amp assembly, attach an ESD wrist strap to yourself. Be sure to ground yourself and the ion chamber frame to dissipate static charges.

Note: The pre-amp assembly is a very delicate and sensitive device. It is important to keep it as clean as possible. Wash and dry your hands thoroughly before working with it and, when possible, use unpowdered latex or cotton gloves. Take care to touch the pre-amp board as little as possible. Take extra care to avoid touching the three air-mounted field inputs. Oils from your fingers on the air-mounts or their components can cause performance degradation.

The 61154A pre-amplifier board can be configured to operate with several different AEC systems. If specified at the time of purchase, the ion chamber will be delivered with the pre-amplifier board already configured for a particular application. To reconfigure an ion chamber for a different configuration, see the section on Ion Chamber Inputs and Output and the section on Specific Configurations at the end of this document.

The procedure assumes that the installation of the Automatic Exposure Control (AEC) is complete and that the AEC and x-ray generator are in proper working condition. After making the necessary interconnections between the ion chamber and the AEC, power up the system.

This document represents proprietary information originated by Advanced Instrument Development, Inc. and which shall not be disclosed or utilized in any manner detrimental to the company's business.

This document describes the calibration of standard "V" or "Y" pattern ion chambers commonly used in medical radiographic equipment, with sensing fields located at the lung and center (spine) positions. The operator selects the field(s) desired, and positions the anatomy of interest in front of the selected field(s). Note that for "Y" pattern ion chambers the two lung fields act together as field "A".

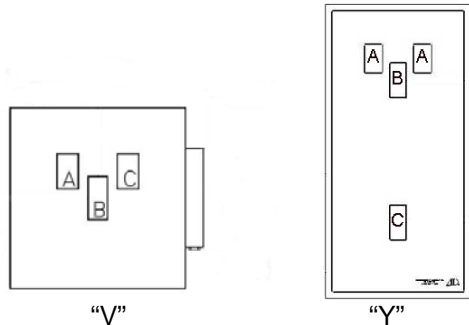

#### Calibration/Test Set Up:

Select the center field of the ion chamber. Set the generator for 100 kVp and maximum backup time. For 100 kVp use 8 to 10 inches (20 to 25 cm) of water or plastic for a phantom. Metals such as copper, aluminum or lead are not suitable for use as phantoms. Make sure the phantom is homogeneous and completely covers all fields equally. Center the x-ray beam on the center field. Collimate the x-ray beam so that it completely covers all three fields but does not extend beyond the limits of the phantom.

#### Adjustment Potentiometers:

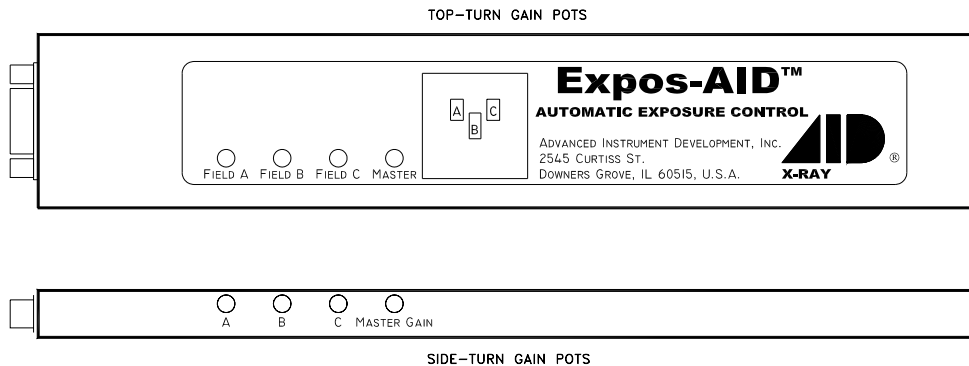

All necessary adjustment potentiometers are accessible through the pre-amp chassis cover. There is no need to open the pre-amp cover during normal calibration procedures.

#### Master Gain Adjustment:

Typically, the master gain adjustment is the only adjustment needed when installing ICX series ion chambers. Use the master gain adjustment to match the overall chamber sensitivity to that of the other stationary chambers connected to the system. Note that the master gain adjustment is a multi-turn potentiometer. A clockwise adjustment to the master gain potentiometer will increase the sensitivity of the chamber, causing the length of the exposure (mAs) to decrease.

Make exposures and process the films. Adjust the master gain for the desired optical density. Make the master gain adjustment for each stationary chamber being installed.

**Field Balance Check:**

Using the AEC post-exposure mAs display or other calibrated mAs meter check the individual fields to see that they are balanced, that is, that they produce the same mAs reading. If mAs readings are not stable from exposure to exposure for an individual field, then it will be necessary to expose films and make these adjustments based upon optical density.

If necessary, adjust the individual gain potentiometers to balance the outputs to give the same mAs reading for each field selected individually. Note that individual gain adjustments are multi-turn potentiometers. A clockwise adjustment to a field gain potentiometer will increase the sensitivity of that field, causing the length of the exposure (mAs) to decrease.

**Ionization Chamber Pin-outs:**

61154A Pre-amp Board Pin-out	Function	9-Pin Sub-D Pin-Out
1	NONE	1
2	FIELD 2 SELECT	2
3	FIELD 1 SELECT	3
4	RESET	4
5	OUTPUT	5
6	FIELD 3 SELECT	6
7	NEGATIVE SUPPLY	7
8	POSITIVE SUPPLY	8
9	GROUND	9

**Acceptable Power Supply Ranges for 61154A Pre-amp:**

Supply Voltage	Measurement Point	Acceptable Range
External +12VDC	61154A pin 8 (referenced to 61154A pin 9)	+11.4VDC to +15.8VDC
External -12VDC	61154A pin 7 (referenced to 61154A pin 9)	-11.4VDC to -15.8VDC
Internal +12VDC	Measure across 61154A C23	+10.8VDC to +12.5VDC
Internal -12VDC	Measure across 61154A C22	-10.8VDC to -12.5VDC
Internal +5VDC	Measure across 61154A C17	+4.7VDC to +5.3VDC
Internal +75VDC	Measure across 61154A C45 (HV1 to G1)	+65VDC to +85.0VDC

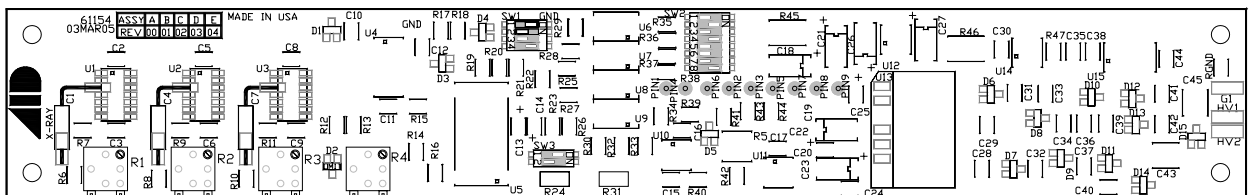

Ionization Chamber Inputs and Output:

Signal	Switch	Comments
Positive Supply +12VDC	None	+11.4VDC to +15.75VDC less than 85 mA.
Negative Supply -12VDC	None	-11.4VDC to -15.75VDC less than 15 mA.
Low-Active Commands Reset & Field Selects	SW1-3 OFF SW1-4 ON	Pulling the Reset line to ground ( $\leq 6VDC$ ) beginning at exposure start and lasting for the entire duration of the exposure allows the integrator to operate. Pulling the field select lines to ground ( $\leq 6VDC$ ) will select the field.
High-Active Commands Reset & Field Selects	SW1-3 ON SW1-4 OFF	Driving the Reset line high ( $\geq 8VDC$ ) beginning at exposure start and lasting for the entire duration of the exposure allows the integrator to operate. Driving the field select lines high ( $\geq 8VDC$ ) will select the field.
Field Configuration A=1, B=2, C=3	SW2-1,5 & 8: ON SW2-2,3,4, 6 & 7: OFF	Field selects 1, 2 and 3 select left (A), center (B) and right (C), respectively, as viewed from the x-ray tube-side of the ion chamber.
Field Configuration A=2, B=1, C=3	SW2-2,4 & 8: ON SW2-1,3,5, 6 & 7: OFF	Field selects 2, 1 and 3 select left (A), center (B) and right (C), respectively, as viewed from the x-ray tube-side of the ion chamber.
Field Configuration A=3, B=1, C=2	SW2-3,4 & 7: ON SW2-1,2,5, 6 & 8: OFF	Field selects 3, 1 and 2 select left (A), center (B) and right (C), respectively, as viewed from the x-ray tube-side of the ion chamber.
Field Configuration A=3, B=2, C=1	SW2-3,5 & 6: ON SW2-1,2,4, 7 & 8: OFF	Field selects 3, 2 and 1 select left (A), center (B) and right (C), respectively, as viewed from the x-ray tube-side of the ion chamber.
Positive Output	SW3-1 ON SW3-2 OFF	Time integrated signal ramping from 0VDC to a maximum of at least 80% of the supply voltage (+9.6VDC for +12VDC supply). The slope of this signal is directly proportional to the amount of x-ray flux received.
Negative Output	SW3-1 OFF SW3-2 ON	Time integrated signal ramping from 0VDC to a maximum of at least 80% of the supply voltage (-9.6VDC for -12VDC supply). The slope of this signal is directly proportional to the amount of x-ray flux received.

Power Supply Isolation:

Signal	Switch	Comments
Power Supply Isolation Defeated	SW1-1 ON	Connects external ground (61154A Pin-9) to pre-amp chassis and ion chamber frame. Default Setting.
Power Supply Isolation Enabled	SW1-1 OFF	Separates external ground (61154A Pin-9) from pre-amp chassis and ion chamber frame to prevent ground loop.

Specific Configurations:

Unless specified otherwise, ICX ion chambers are delivered with an AID compatible jumper configuration. AID compatible means that the input and output signals will interface with Advanced Instrument Development, Inc's Expos-AID™ Automatic Exposure Control. This same configuration will also interface with Acoma, Control-X, CPI, Del Medical (Gendex), Electromed (EMD, Triton), OEC, Quantum Medical Imaging, Sedecal (Innerscan), Summit Industries, etc.

AID Compatible jumper configuration:

Function	Switch Setting
Defeat: Power Supply Isolation	SW1-1 ON
Enable: Alternate Field Selection	SW1-2 OFF
Low-Active Commands: Start Integrate & Field Selects	SW1-3 OFF SW1-4 ON
Field Configuration: A=2, B=1, C=3	SW2-2,4 & 8 ON SW2-1,3,5, 6 & 7 OFF
Positive Output	SW3-1 ON SW3-2 OFF

Alternate configurations are listed below.

GE, Fischer, Varian Compatible jumper configuration:

Function	Switch Setting
Defeat: Power Supply Isolation	SW1-1 ON
Enable: Alternate Field Selection	SW1-2 OFF
High-Active Commands: Start Integrate & Field Selects	SW1-3 ON SW1-4 OFF
Field Configuration: A=1, B=2, C=3	SW2-1,5 & 8 ON SW2-2,3,4, 6 & 7 OFF
Positive Output	SW3-1 ON SW3-2 OFF

GTR Labs Compatible jumper configuration:

Function	Switch Setting
Defeat: Power Supply Isolation	SW1-1 ON
Enable: Alternate Field Selection	SW1-2 OFF
Low-Active Commands: Start Integrate & Field Selects	SW1-3 OFF SW1-4 ON
Field Configuration A=3, B=1, C=2 (= GTR Labs fields 1-2-3)	SW2-3,4 & 7 ON SW2-1,2,5, 6 & 8 OFF
Positive Output	SW3-1 ON SW3-2 OFF

Trex Medical - Continental, Keithley, Ratheon, Xonics Compatible jumper configuration:

Function	Switch Setting
Defeat: Power Supply Isolation	SW1-1 ON
Enable: Alternate Field Selection	SW1-2 OFF
Low-Active Commands: Start Integrate & Field Selects	SW1-3 OFF SW1-4 ON
Field Configuration: A=1, B=2, C=3	SW2-1,5 & 8 ON SW2-2,3,4, 6 & 7 OFF
Positive Output	SW3-1 ON SW3-2 OFF

Trex Medical - Bennett, Health Care Manufacturing Compatible jumper configuration:

Function	Switch Setting
Defeat: Power Supply Isolation	SW1-1 ON
Enable: Alternate Field Selection	SW1-2 OFF
Low-Active Commands: Start Integrate & Field Selects	SW1-3 OFF SW1-4 ON
Field Configuration: A=1, B=2, C=3	SW2-1,5 & 8 ON SW2-2,3,4, 6 & 7 OFF
Negative Output	SW3-1 OFF SW3-2 ON

Picker Compatible jumper configuration:

Function	Switch Setting
Defeat: Power Supply Isolation	SW1-1 ON
Enable: Alternate Field Selection	SW1-2 OFF
Low-Active Commands: Start Integrate & Field Selects	SW1-3 OFF SW1-4 ON
Field Configuration: A=2, B=1, C=3	SW2-2,4 & 8 ON SW2-1,3,5, 6 & 7 OFF
Negative Output	SW3-1 OFF SW3-2 ON

