

Three-field Ionization Chamber  
Calibration Procedure for Pre-Amplifier board 61172

The following adjustments apply to the calibration of a 61172 pre-amplifier board for a stationary 3-field ion chamber, e.g. for chest or table use.

**WARNING:**

- Do not attempt to service the equipment unless this service manual has been consulted and is understood.
- Failure to heed this warning may result in injury to the service provider, operator or patient from electric shock and mechanical or other hazards.

Note: When working with the pre-amplifier assembly it is important that electrostatic discharge (ESD) prevention techniques be observed. Before touching the pre-amp assembly, attach an ESD wrist strap to yourself. Be sure to ground yourself and the ion chamber frame to dissipate static charges.

Note: The pre-amp assembly is a very delicate and sensitive device. It is important to keep it as clean as possible. Wash and dry your hands thoroughly before working with it and, when possible, use unpowdered latex or cotton gloves. Take care to touch the pre-amp board as little as possible. Take extra care to avoid touching the three air-mounted field inputs. Oils from your fingers on the air-mounts or their components can cause performance degradation.

The procedure assumes that the installation of the Automatic Exposure Control (AEC) is complete and that the AEC and x-ray generator are in proper working condition. After making the necessary interconnections between the ion chamber and the AEC, power up the system.

Calibration/Test Set Up:

Your X-Ray Generator/AEC Manual should cover this subject. Calibration procedures are specific to the X-Ray Generator/AEC. The Following is provided as additional information only.

Select the center field of the ion chamber. Set the generator for 100 kVp and maximum backup time. For 100 kVp use 8 to 10 inches (20 to 25 cm) of water or plastic for a phantom. Metals such as copper, aluminum or lead are not suitable for use as phantoms. Make sure the phantom is homogeneous and completely covers all fields equally. Center the x-ray beam on the center field. Collimate the x-ray beam so that it completely covers all three fields but does not extend beyond the limits of the phantom.

This document represents proprietary information originated by Advanced Instrument Development, Inc. and which shall not be disclosed or utilized in any manner detrimental to the company's business.

Adjustment Potentiometers:

All necessary adjustment potentiometers are accessible through the pre-amp chassis cover. There is no need to open the pre-amp cover during normal calibration procedures.

TOP-TURN GAIN POTS

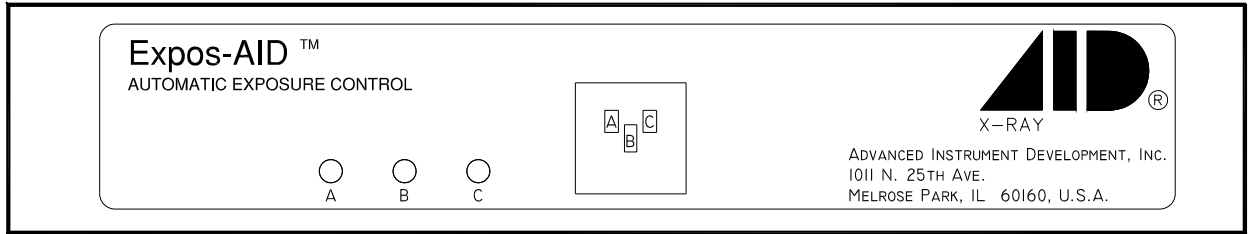

SIDE-TURN GAIN POTS

Field Balance Check:

Using the AEC post-exposure mAs display or other calibrated mAs meter check the individual fields to see that they are balanced, that is, that they produce the same mAs reading. If mAs readings are not stable from exposure to exposure for an individual field, then it will be necessary to expose films and make these adjustments based upon optical density.

The individual gain potentiometers (R1, R2 and R3) correspond to ion chamber A, B and C fields, respectively. These adjustment pots also correspond to the Shimadzu output signals fields 1, 2 and 3, respectively. If necessary, adjust the individual gain potentiometers to balance the outputs to give the same mAs reading for each field. Note that individual gain adjustments are multi-turn potentiometers. A clockwise adjustment to a gain potentiometer will increase the sensitivity of a field, causing the length of the exposure (mAs) to decrease.

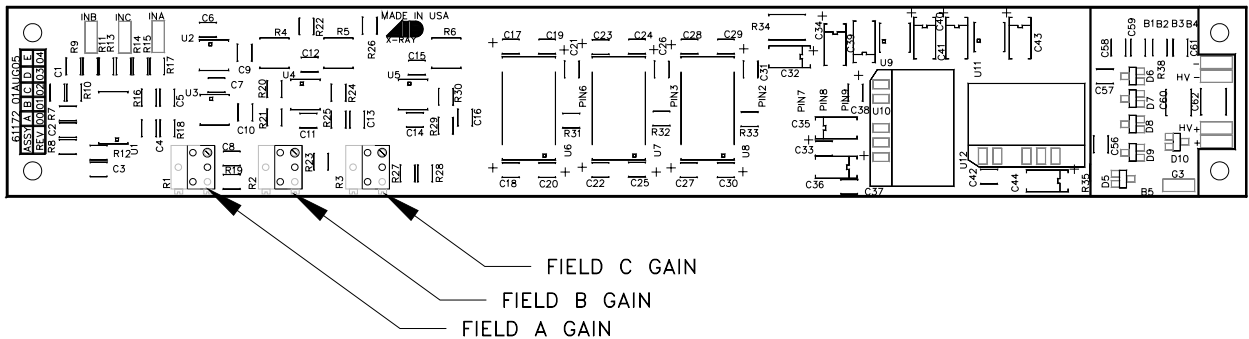

Ionization Chamber Pin-outs:

61172 Pre-amp Board Pin-out	Function	9-Pin Sub-D Connector
2	FIELD 1 OUTPUT	2
3	FIELD 2 OUTPUT	3
6	FIELD 3 OUTPUT	6
7	-15VDC	7
8	+15VDC	8
9	GROUND	9
N/C	NONE	1, 4, 5

Ionization Chamber Inputs and Output:

Signal	Comments
Positive Supply Voltage Range	+11.4VDC to +15.75VDC less than 85 mA.
Negative Supply Voltage Range	-11.4VDC to -15.75VDC less than 15 mA.
Positive DC Level Outputs	DC level signal ranging from 0VDC to a maximum of at least 80% of the supply voltage (+9.6VDC for +12VDC supply). The amplitude of this signal is directly proportional to the amount of x-ray flux received.

Additional cabling will be required to run from the pre-amp to the x-ray generator AEC. The following table lists the pin-out of the 9-pin Sub-D ion chamber cable, AID P/N 75035-XX, that is available in 45, 65 and 85 foot lengths. Specify cable length as a suffix to the cable part number (-XX).

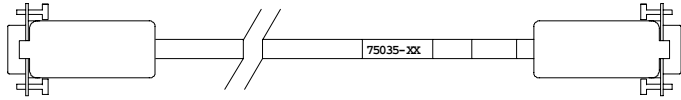
75035-XX			
ION CHAMBER CONNECTOR	ION CHAMBER CABLE WITH STRAIGHT CONNECTOR SHELLS		AEC CONNECTOR
FEMALE 9-PIN SUB-D			MALE 9-PIN SUB-D
PIN NUMBER	WIRE COLOR	FUNCTION	PIN NUMBER
1	BLACK	NONE	1
2	BROWN	FIELD 2 SELECT	2
3	RED	FIELD 1 SELECT	3
4	ORANGE	RESET	4
5	YELLOW	OUTPUT	5
6	GREEN	FIELD 3 SELECT	6
7	BLUE	-15VDC	7
8	VIOLET	+15VDC	8
9	WHITE	GROUND	9
9	CLEAR	SHIELD	N/C

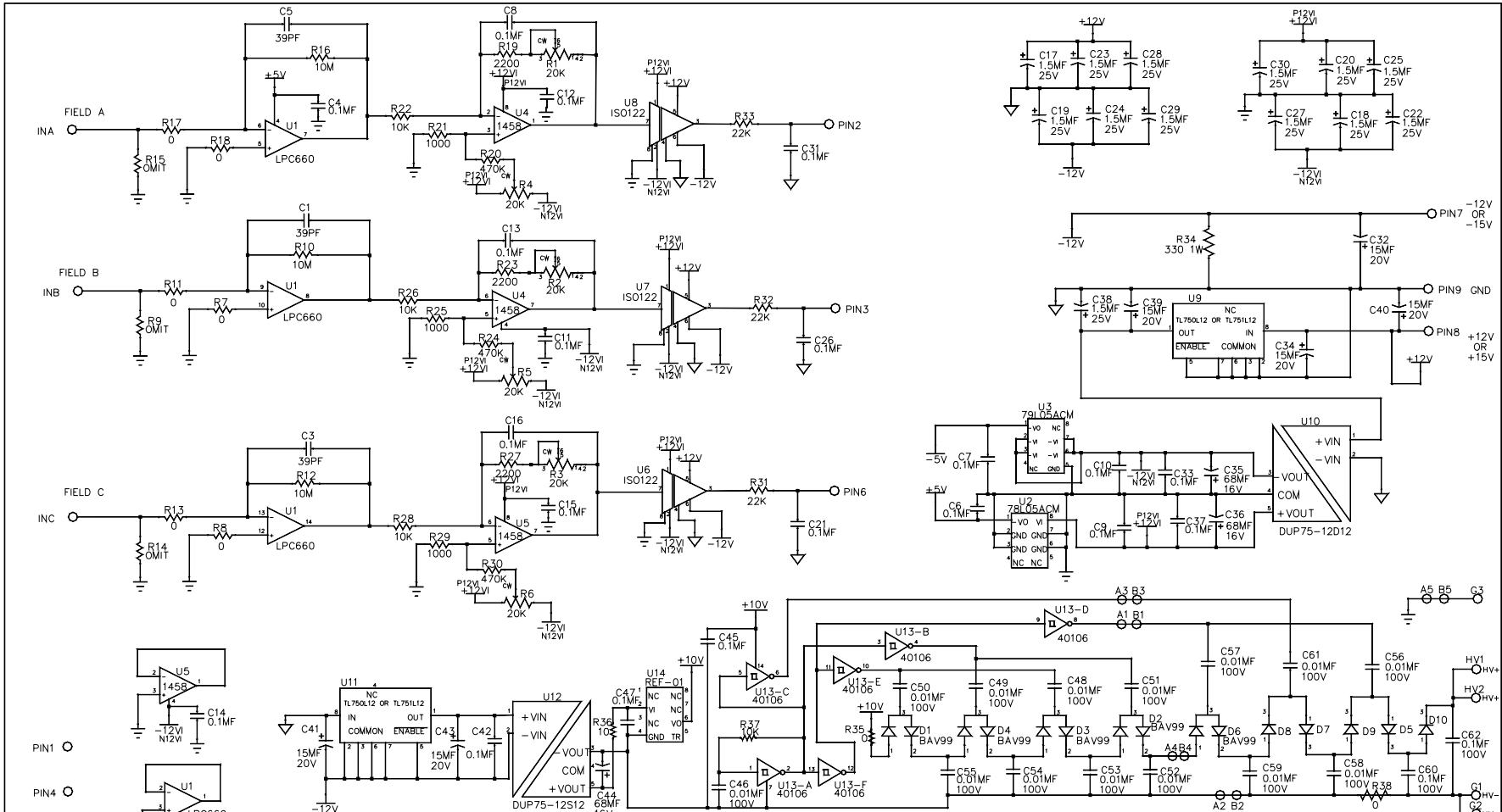

NOTES:  
 1. \* MANUFACTURER MAY USE ALTERNATE COMPONENTS UNLESS NOTED OTHERWISE.

				DO NOT SCALE		ADVANCED INSTRUMENT DEVELOPMENT, INC.	
				UNLESS SPECIFIED OTHERWISE:		1011 N. 25TH AVE.	
				DIMENSIONS ARE IN INCHES		MELROSE PARK, IL 60160	
				FRACTIONS	DEC	ANGLES	
				+/- 1/64	+/- 0.010	+/- 1 DEGREE	
SCALE	NONE	DRAWN BY	TRW	DATE	05APR06	ISOLATED 3-FIELD PRE-AMP	
MATERIAL		CHECKED BY				SHIMADZU COMPATIBLE NEG PULSE OUT	
		APPROVED BY				CALCULATED GAIN RANGE: 0.22 TO 2.22	
00	2297	05APR06	SAME AS 61172C-01 EXCEPT: R22, R26, R28 = 10k, R31, R32, R33 = 22k		SO	USED ON	ICX978
REV	ECN NO.	DATE	REVISIONS		BY	NEXT ASSY.	DRAWING NO.
							61172J
							REV
							00