

Three-field Ionization Chamber  
Calibration Procedure  
for  
Pre-Amplifier board assemblies 61176C

The following adjustments apply to the calibration of a 61176C pre-amplifier board for a stationary 3-field ion chamber, e.g. for chest or table use. The 61176C pre-amplifier board is configured to operate with Siemens AEC systems. (Also valid for 61176S)

Pre-amp Assembly	Description	Difference from 61176C
61176C	Calculated Gain Range = 1.47 to 8.82	None
61176S	Calculated Gain Range = 4.45 to 27.3	R16, R17 & R21 = 2200 ohm

The procedure assumes that the installation of the Automatic Exposure Control (AEC) is complete and that the AEC and x-ray generator are in proper working condition. After making the necessary interconnections between the ion chamber and the AEC, power up the system.

Calibration/Test Set Up:

Select the center field of the ion chamber. Set the generator for 100 kVp and maximum backup time. For 100 kVp use 8 to 10 inches (20 to 25 cm) of water or plastic for a phantom. Metals such as copper, aluminum or lead are not suitable for use as phantoms. Make sure the phantom is homogeneous and completely covers all fields equally. Center the x-ray beam on the center field. Collimate the x-ray beam so that it completely covers all three fields but does not extend beyond the limits of the phantom.

**WARNING:**

- This service manual is available in English and Japanese only.
- If a customer's service provider requires a language other than English, it is the customer's responsibility to provide translation services.
- Do not attempt to service the equipment unless this service manual has been consulted and is understood.
- Failure to heed this warning may result in injury to the service provider, operator or patient from electric shock and mechanical or other hazards.

This document represents proprietary information originated by Advanced Instrument Development, Inc. and which shall not be disclosed or utilized in any manner detrimental to the company's business.

#### Adjustment Potentiometers:

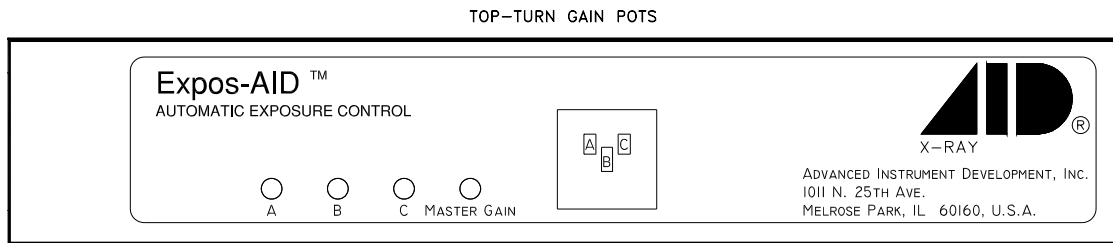

All necessary adjustment potentiometers are accessible through the pre-amp chassis cover. There is no need to open the pre-amp cover during normal calibration procedures.

#### Master Gain Adjustment:

Typically, the master gain adjustment is the only adjustment needed when installing ICX series ion chambers. Use the master gain adjustment to match the overall chamber sensitivity to that of the other stationary chambers connected to the system. Note that the master gain adjustment is a multi-turn potentiometer. A clockwise adjustment to the master gain potentiometer will increase the sensitivity of the chamber, causing the length of the exposure (mAs) to decrease.

Make exposures and process the films. Adjust the master gain for the desired optical density. Make the master gain adjustment for each stationary chamber being installed.

#### Field Balance Check:

Using the AEC post-exposure mAs display or other calibrated mAs meter check the individual fields to see that they are balanced, that is, that they produce the same mAs reading. If mAs readings are not stable from exposure to exposure for an individual field, then it will be necessary to expose films and make these adjustments based upon optical density.

If necessary, adjust the individual gain potentiometers to balance the outputs to give the same mAs reading for each field selected individually. Note that individual gain adjustments are multi-turn potentiometers. A clockwise adjustment to a field gain potentiometer will increase the sensitivity of that field, causing the length of the exposure (mAs) to decrease.

Ionization Chamber Pin-outs:

61176C Pre-amp Board Pin-out	Function	Siemens Signal Name	9-Pin Sub-D Pin-Out
1	NONE	NONE	1
2	FIELD 2 SELECT	DOM II	2
3	FIELD 1 SELECT	DOM I	3
4	FIELD SELECT RETURN	ANA_GND_IONTO	4
5	OUTPUT	RDL A	5
6	FIELD 3 SELECT	DOM III	6
7	NEGATIVE SUPPLY	N_15_A_IONTO	7
8	POSITIVE SUPPLY	P_15_A_IONTO	8
9	GROUND	ANA_GND_IONTO	9

**NOTE:** Cable wire colors do not match those inside the pre-amp chassis. Cable pin-out details are available on-line at <http://www.aidxray.com> or by contacting Advanced Instrument Development, Inc.

Optional Ionization Chamber Cable:

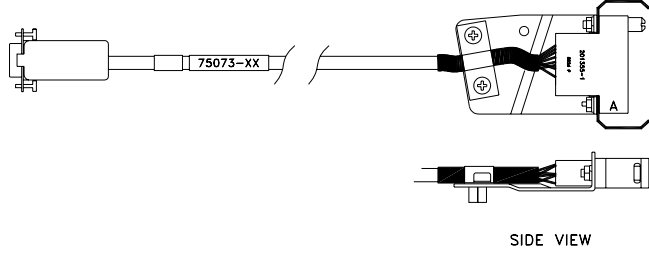
75073-XX (-XX suffix denotes cable length in feet, available in -45, -65 and -85 foot lengths)			
ION CHAMBER CONNECTOR	SIEMENS COMPATIBLE ION CHAMBER CABLE		AEC CONNECTOR
FEMALE 9-PIN SUB-D	 <p style="text-align: center;">SIDE VIEW</p>		FEMALE 14-PIN AMP M SERIES (201355-1)
PIN NUMBER	WIRE COLOR	FUNCTION	PIN NUMBER
1	BLACK	NONE	N/C
2	BROWN	DOM II	L
3	RED	DOM I	B
4	ORANGE	ANA_GND_IONTO	K
5	YELLOW	RDL_A	C
6	GREEN	DOM III	F
7	BLUE	N_15_A_IONTO	D
8	VIOLET	P_15_A_IONTO	E
9	WHITE	ANA_GND_IONTO	H
9	CLEAR	SHIELD	N/C

Ionization Chamber Inputs and Output:

Signal	Switch	Comments
Positive Supply Voltage Range	None	+11.4VDC to +15.8VDC less than 85 mA.
Negative Supply Voltage Range	None	-11.4VDC to -15.75VDC less than 15 mA.
Positive DC Level Output	None	DC level signal ranging from 0VDC to a maximum of at least 80% of the supply voltage (+9.6VDC for +12VDC supply). The amplitude of this signal is directly proportional to the amount of x-ray flux received.
High-Active Field Selects	None	Driving the field select lines high ( $\geq 8\text{VDC}$ ) will select the field.
Field Configuration A=1, B=2, C=3	SW2-1,5 & 8 ON SW2-2,3,4, 6 & 7 OFF	Field selects 1, 2 and 3 select left (A), center (B) and right (C), respectively, as viewed from the x-ray tube-side of the ion chamber.
Field Configuration A=2, B=1, C=3	SW2-2,4 & 8 ON SW2-1,3,5, 6 & 7 OFF	Field selects 2, 1 and 3 select left (A), center (B) and right (C), respectively, as viewed from the x-ray tube-side of the ion chamber.
Field Configuration A=3, B=1, C=2	SW2-3,4 & 7 ON SW2-1,2,5, 6 & 8 OFF	Field selects 3, 1 and 2 select left (A), center (B) and right (C), respectively, as viewed from the x-ray tube-side of the ion chamber.
Field Configuration A=3, B=2, C=1	SW2-3,5 & 6 ON SW2-1,2,4, 7 & 8 OFF	Field selects 3, 2 and 1 select left (A), center (B) and right (C), respectively, as viewed from the x-ray tube-side of the ion chamber.

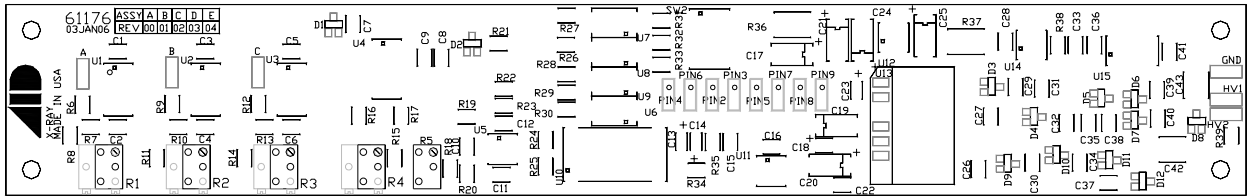

Acceptable Power Supply Ranges for 61176C Pre-amp:

Supply Voltage	Measurement Point	Acceptable Range
Pos. Input Supply Voltage	61176C pin 8 (Referenced to 61176C pin 9)	From +11.4VDC to +15.8VDC
Neg. Input Supply Voltage	61176C pin 7 (Referenced to 61176C pin 9)	From -11.4VDC to -15.8VDC
Internal +12VDC Regulated on board	Measure across 61176C C9	From +10.8VDC to +12.5VDC
Internal +12VDC Isolated	Measure across 61176C C38	From +10.8VDC to +12.5VDC
Internal -12VDC Isolated	Measure across 61176C C31	From -10.8VDC to -12.5VDC
Internal +5VDC Regulated on board	Measure across 61176C C29	From +4.7VDC to +5.3VDC
+75VDC Internal Bias Voltage Regulated on board	Measure across 61176C C21 (HV1 to GND)	From +65VDC to +85.0VDC

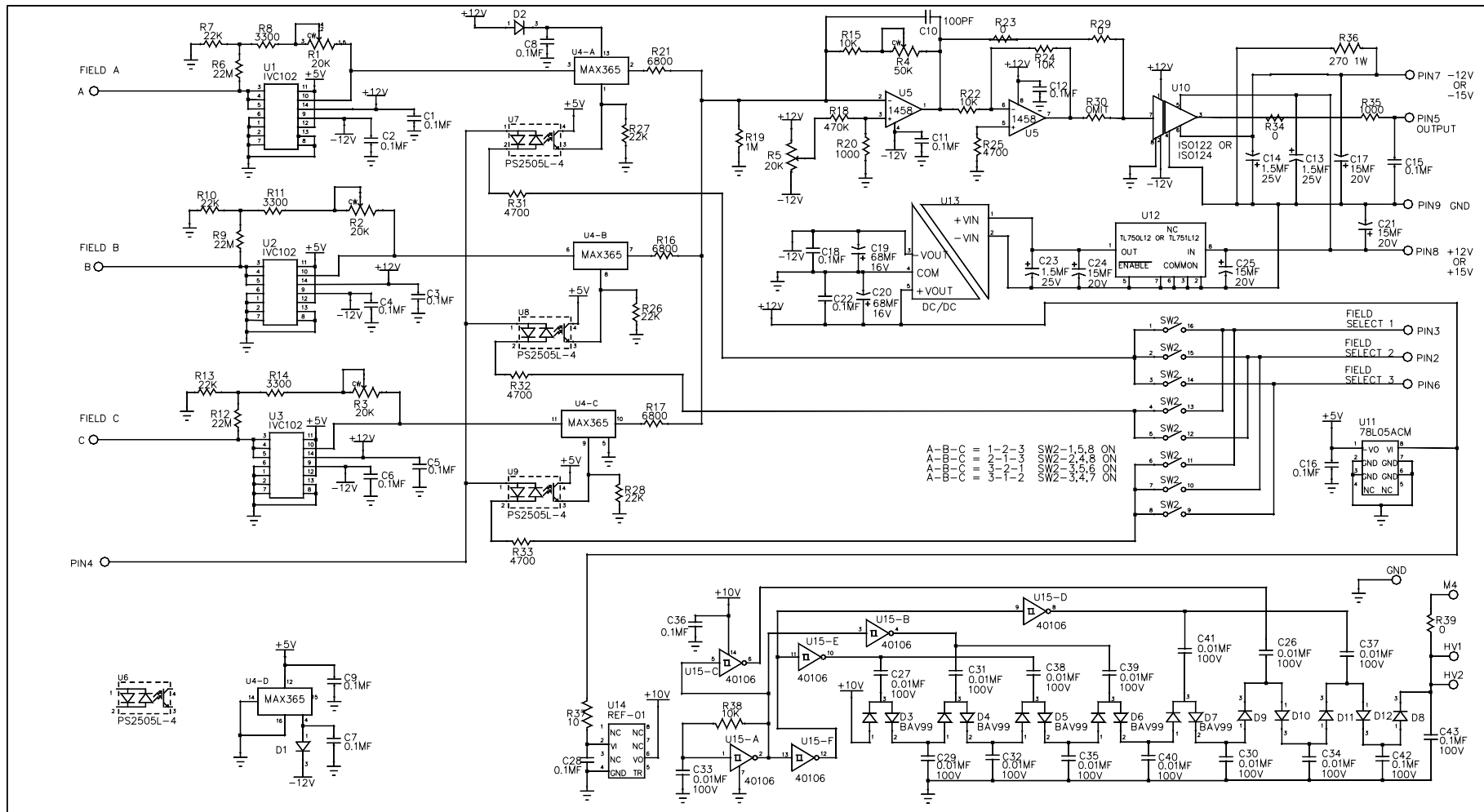

NOTES:

- \* MANUFACTURER MAY USE ALTERNATE COMPONENTS UNLESS NOTED OTHERWISE.
- ALL SWITCHES OFF UNLESS OTHERWISE NOTED.
- U6,U7,U8, AND U9 MAY BE (4) SINGLE, (2) DUAL, OR (1) QUAD DEVICES.

					DO NOT SCALE			ADVANCED INSTRUMENT DEVELOPMENT, INC.	
					UNLESS SPECIFIED OTHERWISE: DIMENSIONS ARE IN INCHES			1011 N. 25TH AVE. MELROSE PARK, IL 60160	
					FRACTIONS +/- 1/64	DEC. +/- 0.010	ANGLES +/- 1 DEGREE	X-RAY	
SCALE	NONE	DRAWN BY	TRW	DATE	10DEC01	ISOLATED 3-FIELD SIEMENS PRE-AMP CALCULATED GAIN = 1.47 TO 8.82 TOP-TURN POTS			
MATERIAL		CHECKED BY				USED ON	NEXT ASSY.	DRAWING NO.	REV
FINISH		APPROVED BY				ICX SERIES		61176C	00
Q0	2339	18JAN06	61166 BOARD WITH THROUGH HOLE POTS	TRW	THIS DRAWING REPRESENTS PROPRIETARY AND CONFIDENTIAL INFORMATION ORIGINATED BY ADVANCED INSTRUMENT DEVELOPMENT, INC. AND WHICH SHALL NOT BE DISCLOSED OR UTILIZED IN ANY MANNER DETRIMENTAL TO THE COMPANY BUSINESS.				
REV	ECN NO.	DATE	REVISIONS	BY					