

ICX997
Three-field Ionization Chamber
Calibration Procedure for Pre-Amplifier board 61154U

The ICX997 ion chamber is used in several GEHC models as outlined below:

GEHC P/N	Description	Use AID P/N
5167409	ICX997 alone	ICX997
5167409-1	ICX997 and 75086M04	705325
5167409-2	ICX997 and 75086M24	705326

The model ICX997 connects via a male 15-pin Amp Modu connector. Refer to page 4 of this document for interface cable pin-out details.

Use the hexagonal and tubular spacers, provided, to mount the ICX997 in the Bucky.

The following adjustments apply to the calibration of the 61154U pre-amplifier board used with the model ICX997 three-field ion chamber.

WARNING:

- This service manual is normally supplied in English. Other languages* available on request..
- Do not attempt to service the equipment unless this service manual has been consulted and is understood.
- Failure to heed this warning may result in injury to the service provider, operator or patient from electric shock and mechanical or other hazards.

Note: When working with the pre-amplifier assembly it is important that electrostatic discharge (ESD) prevention techniques be observed. Before touching the pre-amp assembly, attach an ESD wrist strap to yourself. Be sure to ground yourself and the ion chamber frame to dissipate static charges.

Note: The pre-amp assembly is a very delicate and sensitive device. It is important to keep it as clean as possible. Wash and dry your hands thoroughly before working with it and, when possible, use unpowdered latex or cotton gloves. Take care to touch the pre-amp board as little as possible. Take extra care to avoid touching the three air-mounted field inputs. Oils from your fingers on the air-mounts or their components can cause performance degradation.

This document represents proprietary information originated by Advanced Instrument Development, Inc. and which shall not be disclosed or utilized in any manner detrimental to the company's business.

* French, German, Spanish, Japanese

CABLE LENGTH

1000 \pm 50

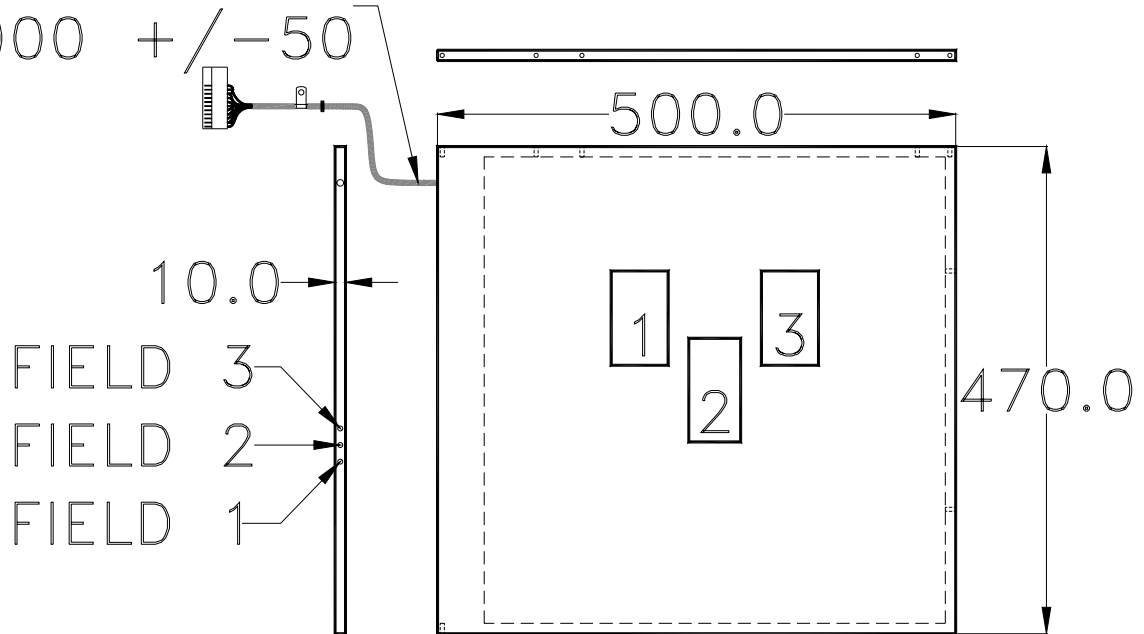

The procedure assumes that the installation of the Automatic Exposure Control (AEC) is complete and that the AEC and the x-ray generator are in proper working condition. After making the necessary interconnections between the ion chamber and the AEC, power up the system.

Calibration/Test Set Up:

Select the center field of the ion chamber. Set the generator for 100 kVp and maximum backup time. For 100 kVp, use 8 to 10 inches (20 to 25 cm) of water or plastic for a phantom. Metals such as copper, aluminum or lead are not suitable for use as phantoms. Make sure the phantom is homogeneous and completely covers all fields equally. Center the x-ray beam on the center field. Collimate the x-ray beam so that it completely covers all three fields but does not extend beyond the limits of the phantom.

Balance Check:

Using the AEC post-exposure mAs display or other calibrated mAs meter check the individual fields to see that they are balanced, that is, that they produce the same mAs reading. If mAs readings are not stable from exposure to exposure for an individual field, then it will be necessary to expose films and make these adjustments based upon optical density.

The individual gain potentiometers, 61154U R1, R2 and R3, correspond to ion chamber fields 1, 2 and 3, respectively. If necessary, adjust the individual gain potentiometers to balance the outputs to give the same mAs reading for each field. Note that individual gain adjustments are multi-turn potentiometers. A clockwise adjustment to a gain potentiometer will increase the sensitivity of a field, causing the length of the exposure (mAs) to decrease.

Ionization Chamber Pin outs:

MALE 15-PIN MODU PIN NUMBER	FUNCTION	61154U PRE-AMP BOARD PAD NUMBER
1 - 4	NONE	N/C
5 Jumper to pin 7	0V (Vout)	9
6	Vout: Integration Ramp	5
7 Jumper to pin 14	0V (Vout)	9
8	0/24VDC or (-15/+15V) Start Integration	4
9	0/24VDC or (-15/+15V) for area 3 selection (right cellule)	6
10	0/24VDC or (-15/+15V) for area 2 selection (central cellule)	2
11	0/24VDC or (-15/+15V) for area 1 selection (left cellule)	3
12	Common return for areas selection and start integration	1
13	-15VDC Supply	7
14	0V common for +/-15V	9
15	+15VDC Supply	8

NOTE: Cable wire colors do not match those inside the pre-amp chassis. Cable pin-out details are available on-line at <http://www.aidxray.com> or by contacting Advanced Instrument Development, Inc.

Pre-amplifier Switch Settings:

Function	Switch Setting
Defeat: Power Supply Isolation	SW1-1 ON
Enable: Alternate Field Selection	SW1-2 OFF
High-Active Commands: Start Integrate & Field Selects	SW1-3 ON SW1-4 OFF
Field Configuration: A=1, B=2, C=3	SW2-1,5 & 8 ON SW2-2,3,4, 6 & 7 OFF
Positive Output	SW3-1 ON SW3-2 OFF

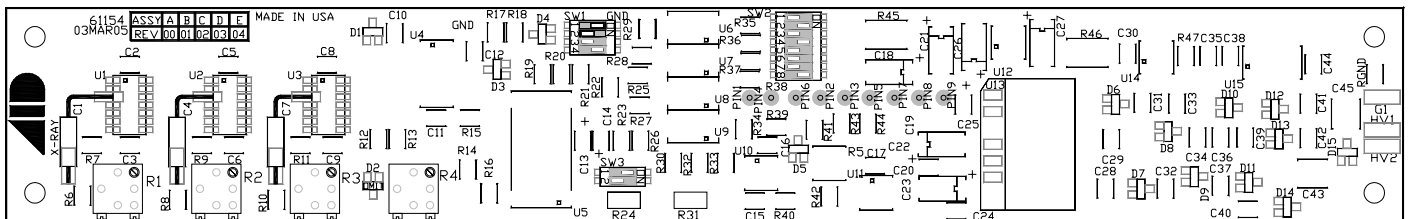

Acceptable Power Supply Ranges for 61154U Pre-amp:

Supply Voltage	Measurement Point	Acceptable Range
External +15VDC	61154U pin 8	+11.4VDC to +15.8VDC
External -15VDC	61154U pin 7	-11.4VDC to -15.8VDC
Internal +12VDC	Measure across 61154U C23	+10.8VDC to +12.5VDC
Internal -12VDC	Measure across 61154U C22	-10.8VDC to -12.5VDC
Internal +5VDC	61154U C17 (positive lead)	+4.7VDC to +5.3VDC
Internal +75VDC	61154U HV1	+65VDC to +85.0VDC

All readings are referenced to ground at 61154U pin 9 or 15-pin Modu connector pin 14.

AID P/N 75091M04 (GEHC P/N 5166493) 4-METER CABLE LENGTH, AID P/N 75091M24 (GEHC P/N 5166654) 24-METER CABLE LENGTH			
ION CHAMBER CONNECTOR	ICX997 INTERCONNECTION CABLE (FOR GEHC EUROPEAN PIN-OUT MPH GENERATORS)		AEC CONNECTOR
FEMALE 15-PIN AMP MODU			FEMALE 14-PIN AMP M SERIES (201298-1)
PIN NUMBER	WIRE COLOR	FUNCTION	PIN NUMBER
1	VIOLET (RED/BLK)	NONE	P
2, 3, 4	NONE	NONE	N/C
5	YELLOW (ORG/BLK)	0V (Vout)	L
6	GREEN	Vout: Integration Ramp	D
7	BLUE	0V (Vout)	M
8	WHITE/BROWN (BLK/WHT)	0/24VDC or (-15/+15V) Start Integration	H
9	WHITE/BLACK	0/24VDC or (-15/+15V) for area 3 selection (right cellule)	F
10	WHITE	0/24VDC or (-15/+15V) for area 2 selection (central cellule)	K
11	GREY (BLU/WHT)	0/24VDC or (-15/+15V) for area 1 selection (left cellule)	J
12	ORANGE	Common return for areas selection and start integration	E
13	RED	-15VDC Supply	C
14	BROWN (ORG/BLK)	0V common for +/-15V	B
15	BLACK	+15VDC Supply	A
P-CLAMP	CLEAR	Shield	R

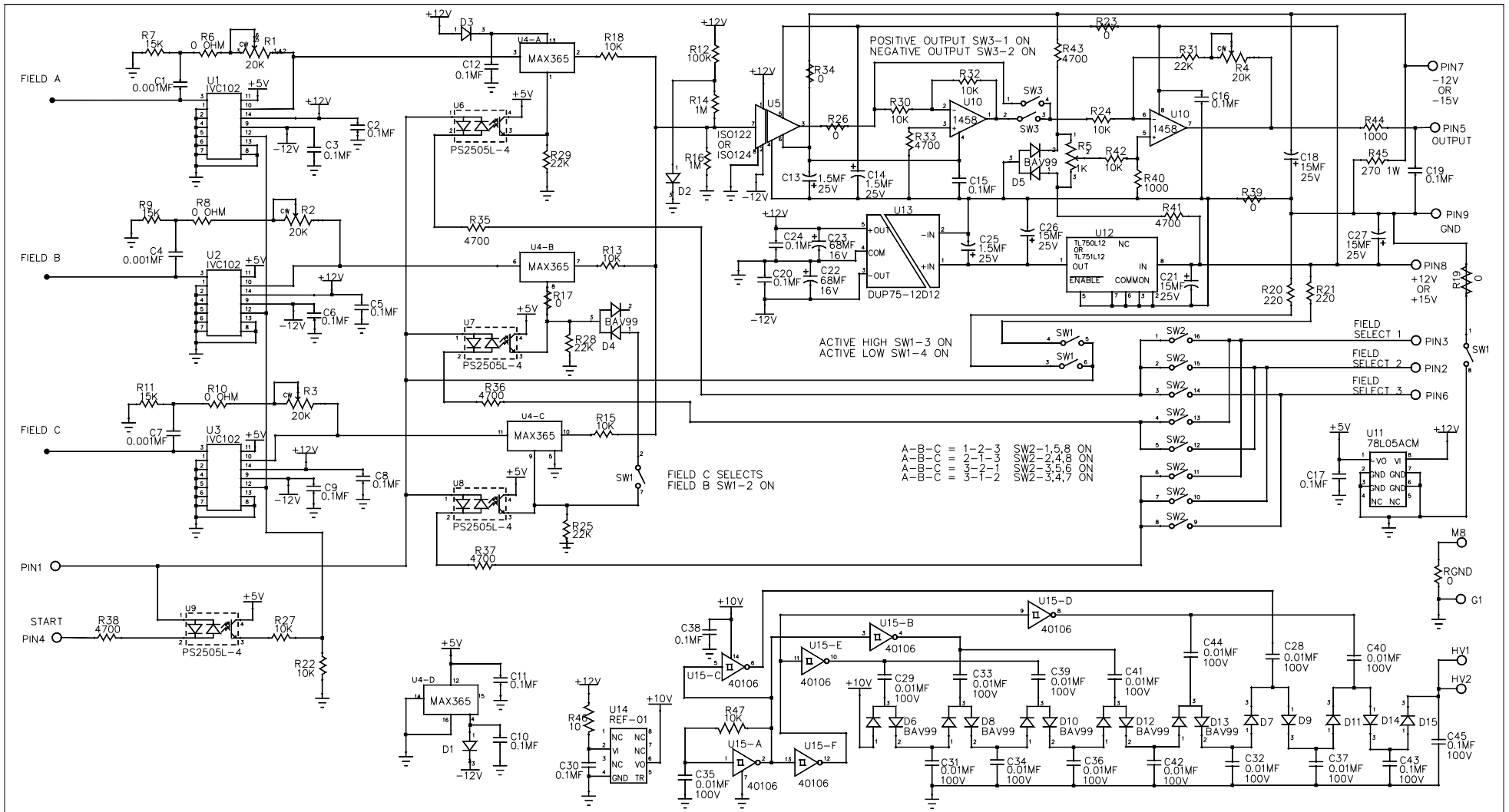

A-B-C = 1-2-3 SW2-1,5,8 ON
 A-B-C = 2-1-3 SW2-2,4,8 ON
 A-B-C = 3-2-1 SW2-3,5,6 ON
 A-B-C = 3-1-2 SW2-3,4,7 ON

FIELD C SELECTS
 FIELD B SW1-2 ON

- NOTES:
- * MANUFACTURER MAY USE ALTERNATE COMPONENTS UNLESS NOTED OTHERWISE.
 - ALL SWITCHES OFF UNLESS OTHERWISE NOTED.
 - U6,U7,U8, AND U9 MAY BE (4) SINGLE OR (1) QUAD DEVICE.

				DO NOT SCALE		ADVANCED INSTRUMENT DEVELOPMENT, INC. 1011 N. 25TH AVE. MELROSE PARK, IL. 60160 								
				UNLESS SPECIFIED OTHERWISE; DIMENSIONS ARE IN INCHES. FRACTIONS DECIMALS ANGLES $\pm 1/64$ ± 0.010 $\pm 1^\circ$										
00	2276	20APR05	SAME AS 61154A EXCEPT:	BRP	SCALE	NONE	DRAWN BY	BRP	DATE	17MAY05	3-FIELD ISOLATED PRE-AMP LOW-PROFILE SIDE-TURN POTS (POT R4 FOR AID TEST DEPT. ADJ. ONLY)			
			R6, R8, R10 = 0 OHM; R7, R9, R11 = 15K		MATERIAL	NONE	CHECKED BY							
			R12 = 100K; R14 = 1M; D2 = D914		FINISH	NONE	APPROVED BY							
			R24 = 10K, R31 = 22K		THIS DRAWING REPRESENTS PROPRIETARY AND CONFIDENTIAL INFORMATION ORIGINATED BY ADVANCED INSTRUMENT DEVELOPMENT, INC. AND WHICH SHALL NOT BE DISCLOSED OR UTILIZED IN ANY MANNER DETRIMENTAL TO THE COMPANY'S BUSINESS.		USED ON	ICX937, ICX967, ICX997	NEXT ASSY	71445, 71446, 71500	DRAWING NO.	61154U	REV.	00