

ICX250 3-of-5 Field Tilt-Sensing Ionization Chamber

Calibration Procedure for
Pre-Amplifier board assembly 61179R

The following adjustments apply to the calibration of a 61179R pre-amplifier board for a stationary 3-of-5 field ion chamber, e.g. for chest or table use.

WARNING:

- Do not attempt to service the equipment unless this service manual has been consulted and is understood.
- Failure to heed this warning may result in injury to the service provider, operator or patient from electric shock and mechanical or other hazards.

Note: When working with the pre-amplifier assembly it is important that electrostatic discharge (ESD) prevention techniques be observed. Before touching the pre-amp assembly, attach an ESD wrist strap to yourself. Be sure to ground yourself and the ion chamber frame to dissipate static charges.

Note: The pre-amp assembly is a very delicate and sensitive device. It is important to keep it as clean as possible. Wash and dry your hands thoroughly before working with it and, when possible, use unpowdered latex or cotton gloves. Take care to touch the pre-amp board as little as possible. Take extra care to avoid touching the three air-mounted field inputs. Oils from your fingers on the air-mounts or their components can cause performance degradation.

This document represents proprietary information originated by Advanced Instrument Development, Inc. and which shall not be disclosed or utilized in any manner detrimental to the company's business.

The procedure assumes that the installation of the Automatic Exposure Control (AEC) is complete and that the AEC and x-ray generator are in proper working condition. After making the necessary interconnections between the ion chamber and the AEC, power up the system.

The 61179R pre-amplifier board can be configured to operate with several different AEC systems. If specified at the time of purchase, the ion chamber will be delivered with the pre-amplifier board already configured for a particular application. To reconfigure an ion chamber for a different configuration, see the section on Ion Chamber Inputs and Output and the section on Specific Configurations at the end of this document.

Calibration/Test Set Up:

Your X-Ray Generator/AEC Manual should cover this subject. Calibration procedures are specific to the X-Ray Generator/AEC. The Following is provided as additional information only.

Select the center field of the ion chamber. Set the generator for 100 kVp and maximum backup time. For 100 kVp use 8 to 10 inches (20 to 25 cm) of water or plastic for a phantom. Metals such as copper, aluminum or lead are not suitable for use as phantoms. Make sure the phantom is homogeneous and completely covers all fields equally. Center the x-ray beam on the center field. Collimate the x-ray beam so that it completely covers all three fields but does not extend beyond the limits of the phantom.

Adjustment Potentiometers:

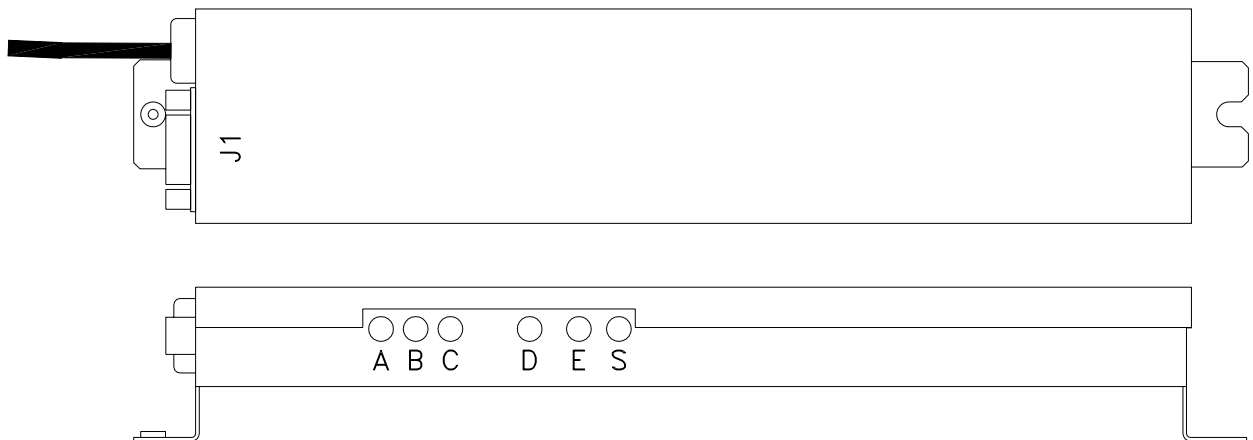

All necessary adjustment potentiometers are accessible through the pre-amp chassis cover. There is no need to open the pre-amp cover during normal calibration procedures.

Master Gain Adjustment:

The master gain adjustment should be used to adjust the ion chamber to produce the correct optical density (OD) while only the Center Field (Field B) is selected. A replacement ion chamber's film optical density should usually be matched to that of other stationary ion chambers connected to the system. Note that the master gain adjustment is a multi-turn potentiometer. A clockwise adjustment to the master gain potentiometer will increase the sensitivity of the chamber, causing the length of the exposure (mAs) to decrease.

Make an exposure and record the post exposure mAs reading. Process the film. Measure and record the film optical density. Adjust the master gain for the desired optical density (normally between 1.1 and 1.8 OD, depending upon the user). Make the master gain adjustment using this formula:

$$\text{Desired mAs} = (\text{Desired OD} / \text{Measured OD}) \times \text{Measured mAs}$$

Note: Make sure that a film cassette is present while making all exposures. Cassette backscatter affects AEC operation.

Field Balance Check:

Using the AEC post-exposure mAs display or other calibrated mAs meter check the individual fields to see that they are balanced, that is, that they produce the same mAs reading. If mAs readings are not stable from exposure to exposure for an individual field, then it will be necessary to expose films and make these adjustments based upon optical density.

If necessary, adjust the individual gain potentiometers to balance the outputs to give the same mAs reading for each field selected individually.

Note that individual gain adjustments are multi-turn potentiometers. A clockwise adjustment to a field gain potentiometer will increase the sensitivity of that field, causing the length of the exposure (mAs) to decrease.

ICX250 Ionization Chamber Pin-outs:

61179R Pre-amp Board Pin-out	Pre-amp Chassis Wire Color	Function	9-Pin Sub-D Pin-Out
N/C	BLACK	NONE	1
2	BROWN	CENTER FIELD SELECT	3
3	RED	LEFT FIELD SELECT	2
4	ORANGE	OUTPUT	5
5	YELLOW	START INTEGRATING	4
6	GREEN	RIGHT FIELD SELECT	6
7	BLUE	NEGATIVE SUPPLY	7
8	VIOLET	POSITIVE SUPPLY	8
9	GRAY	GROUND	9

NOTE: Cable wire colors do not match those inside the pre-amp chassis. Cable pin-out details are available on-line at <http://www.aidxray.com> or by contacting Advanced Instrument Development, Inc.

TILT SWITCH SETTING	FIELD SELECTED
VERTICAL	A
HORIZONTAL/HEAD-END LEFT	D
HORIZONTAL/HEAD-END RIGHT	C
VERTICAL	C
HORIZONTAL/HEAD-END LEFT	A
HORIZONTAL/HEAD-END RIGHT	E

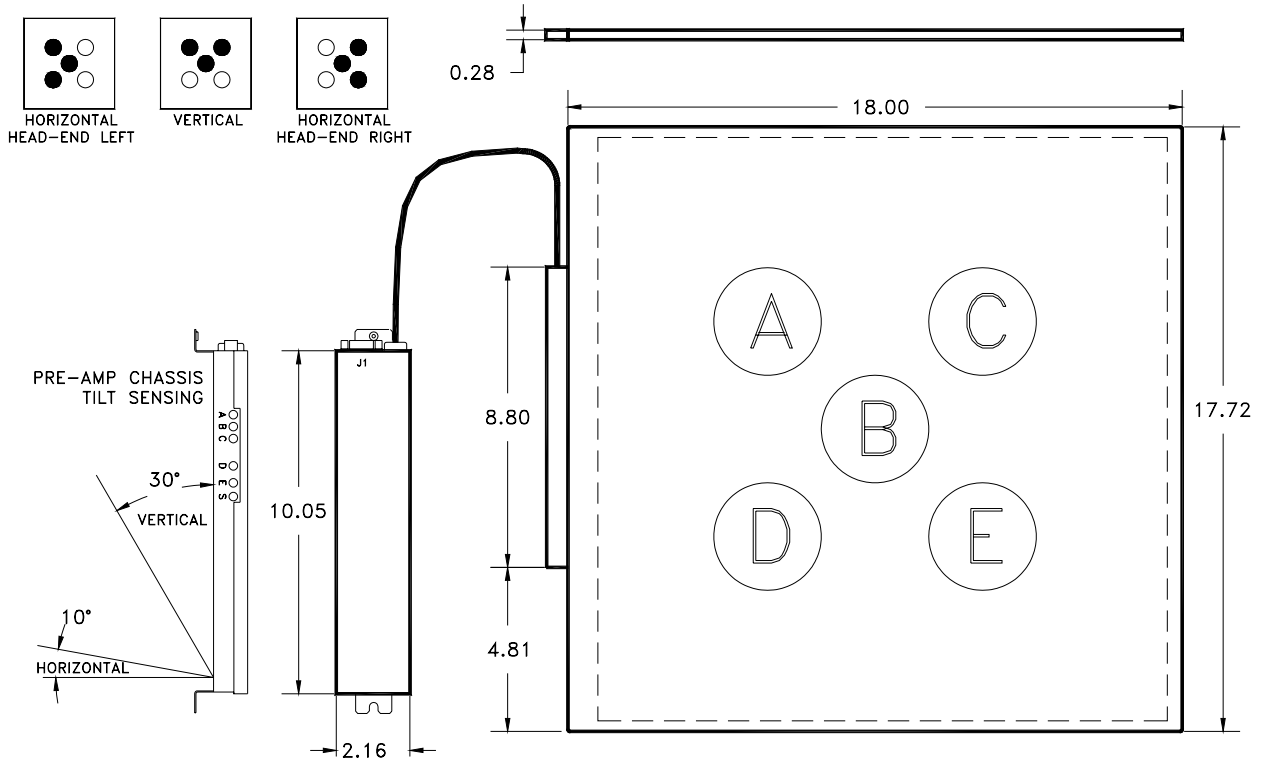

Specific Configurations:

Unless specified otherwise, the ICX250 ion chamber is delivered with a GE compatible jumper configuration.

GE, Fischer, Varian Compatible jumper configuration:
Positive Output; High-Active Field Selects and Reset

61179R Switch	Position	Function
SW1-1	ON	Positive output signal (enabled)
SW1-2	OFF	Negative output signal (disabled)
SW2-1	ON	High -active field selects & reset (enabled)
SW2-2	OFF	Low-active field selects & reset (disabled)
SW3-1	ON	Frame ground on
SW3-2	OFF	Horizontal head-end-left

AID Compatible jumper configuration:
Positive Output; Low-Active Field Selects and Reset

61179R Switch	Position	Function
SW1-1	ON	Positive output signal (enabled)
SW1-2	OFF	Negative output signal (disabled)
SW2-1	OFF	High -active field selects & reset (disabled)
SW2-2	ON	Low-active field selects & reset (enabled)
SW3-1	ON	Frame ground on
SW3-2	OFF	Horizontal head-end-left

AID compatible means that the input and output signals will interface with Advanced Instrument Development, Inc's Expos-AID™ Automatic Exposure Control. This same configuration will also interface with Acoma, Control-X, CPI, Del Medical (Gendex), Electromed (EMD, Triton), OEC, Quantum Medical Imaging, Sedecal (Innerscan), Summit Industries, etc.

Hologic/Trex Medical - Continental, Keithley, Ratheon, Xonics Compatible jumper configuration:
Positive Output; Low-Active Field Selects and Reset

61179R Switch	Position	Function
SW1-1	ON	Positive output signal (enabled)
SW1-2	OFF	Negative output signal (disabled)
SW2-1	OFF	High -active field selects & reset (disabled)
SW2-2	ON	Low-active field selects & reset (enabled)
SW3-1	ON	Frame ground on
SW3-2	OFF	Horizontal head-end-left

Hologic/Trex Medical - Bennett Compatible jumper configuration:
Negative Output; Low-Active Field Selects and Reset

61179R Switch	Position	Function
SW1-1	OFF	Positive output signal (disabled)
SW1-2	ON	Negative output signal (enabled)
SW2-1	OFF	High -active field selects & reset (disabled)
SW2-2	ON	Low-active field selects & reset (enabled)
SW3-1	ON	Frame ground on
SW3-2	OFF	Horizontal head-end-left

Advanced Instrument Development, Inc.

2545 Curtiss St.

Downers Grove, IL 60515 U.S.A.

Phone: (630) 271-9729

www.aidxray.com

Fax: (630) 271-9995

Picker Compatible jumper configuration:
Negative Output; Low-Active Field Selects and Reset

61179R Switch	Position	Function
SW1-1	OFF	Positive output signal (disabled)
SW1-2	ON	Negative output signal (enabled)
SW2-1	OFF	High -active field selects & reset (disabled)
SW2-2	ON	Low-active field selects & reset (enabled)
SW3-1	ON	Frame ground on
SW3-2	OFF	Horizontal head-end-left

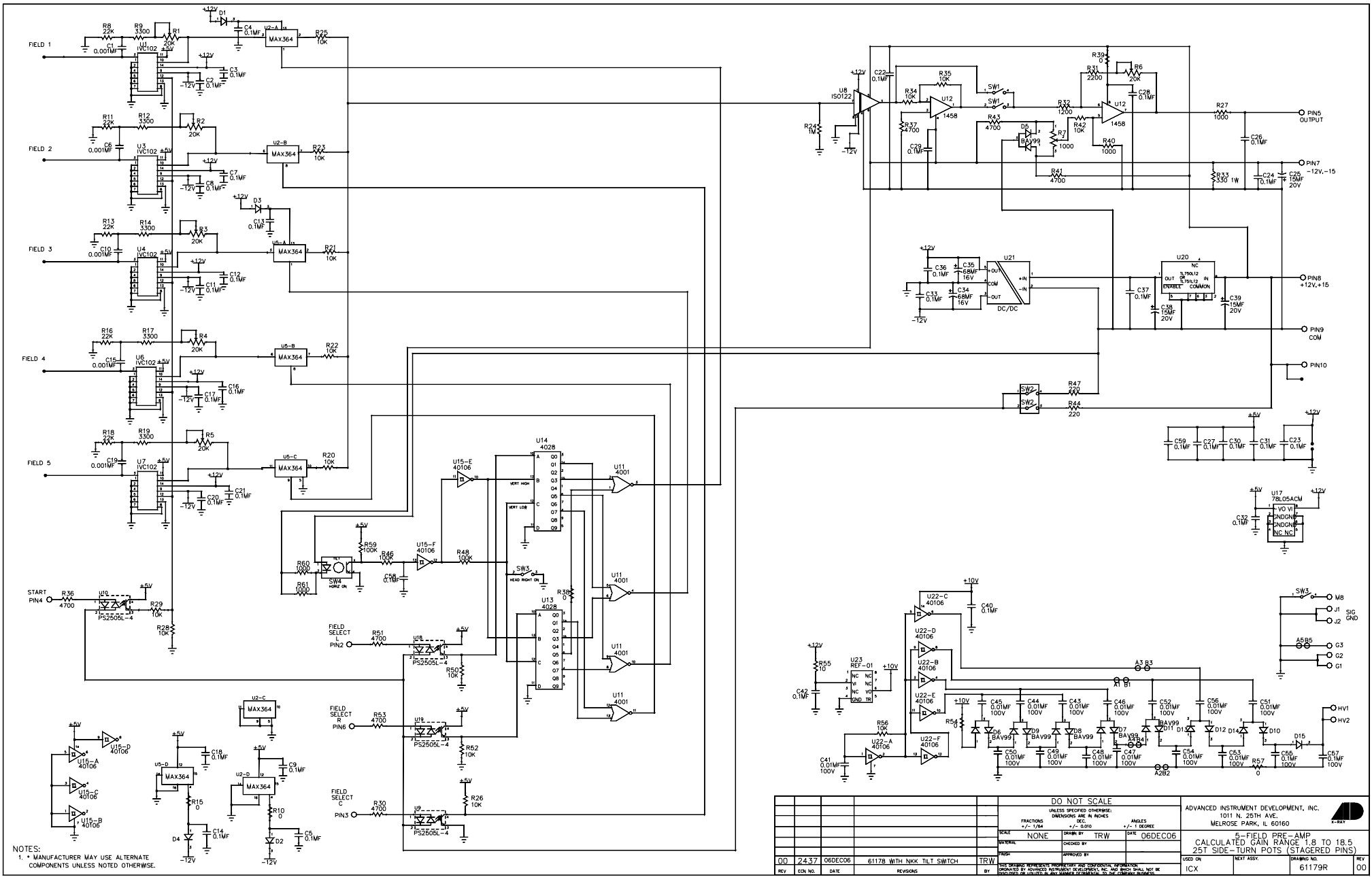

DO NOT SCALE				ADVANCED INSTRUMENT DEVELOPMENT, INC.	
UNLESS SHOWN OTHERWISE, DIMENSIONS ARE IN INCHES				1011 N. 25TH AVE.	
SCALE: FRACTIONS +/- 1/64 DECIMAL +/- 0.010 ANGLE +/- 1 DEGREE				MELROSE PARK, IL 60160	
GENERAL:	NONE	DRAWN BY:	TRW	DATE:	06DEC06
TITLE:		CHECKED BY:			
THIS DRAWING REPRESENTS PROPERTY AND CONFIDENTIAL INFORMATION OF ADVANCED INSTRUMENT DEVELOPMENT, INC. AND SHALL NOT BE REPRODUCED OR TRANSMITTED IN ANY FORM OR BY ANY MEANS, ELECTRONIC OR MECHANICAL, WITHOUT PERMISSION.				USED ON:	ICX
REV:	EDN NO.	DATE:	REVISIONS:	BY:	REV:
00	2437	06DEC06	61178 WITH NKK TILT SWITCH	TRW	00
				NEXT ASSY:	DRAWING NO. 61179R